

ADA Survey



1 Main St
Your Town, CO

Prepared for: Sample

Prepared by: Colorado Inspection Services, LLC

Table of Contents

General	2
Approach and Entry	3
Protruding Objects	4
Parking	5
Entry	8
Mailbox Kiosks	10
Common Areas	11
Alarms	14
Interior Doors	15
Ramps	17
Elevators	20
Stairs	25
Restrooms	26
Signs	51
Apartments	53
Apartment Controls	60
Kitchens	64
Bathrooms	71
Exercise Equipment	86
Pool	87
Summary	89



Colorado Inspection Services, LLC

Prepared for:
1 Main St

General

General

Property Information

Property Address 1 Main St
City Your Town State CO Zip
Contact Name Property manager Ken

Client Information

Inspection Company

Inspector Name Carl Brahe
Company Name Colorado Inspection Services, LLC
Phone 303 816-5556
Email carl@coinspection.com

General (Continued)

Approach and Entry

Approach and Entry II

Acceptable Is there at least one route from site arrival points (parking, passenger loading zones, public sidewalks and public transportation stops) that does not require the use of stairs?
[See 2010 ADA Standards for Accessible Design 206.2.1]

Exterior Accessible Route

Acceptable Is the route stable, firm and slip-resistant?
[302.1]

Acceptable Is the route at least 36 inches wide?
[403.5.1]



Acceptable For each section of the ramp, is the running slope no greater than 1:12, i.e. for every inch of height change there are at least 12 inches of ramp run?
[405.2]

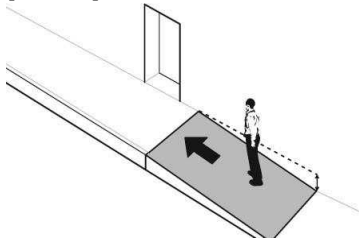

Note: If the running slope is steeper than 1:20, treat as a ramp and add features such as edge protection and handrails

Acceptable Is the cross slope no steeper than 1:48?
[403.3]

Approach and Entry (Continued)

Protruding Objects

Apartment Protruding Objects

Protruding Objects

Acceptable Do wall mounted objects located between 27 and 80 inches above the finished floor have leading edges that do not protrude more than 4 inches from the wall?

Note: The protruding object requirement applies to all circulation paths (e.g., hallways, passageways, aisles, routes, etc.).

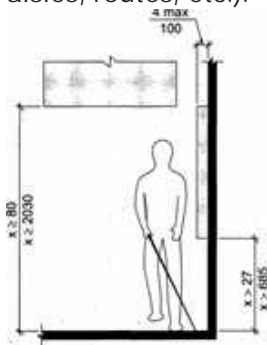

Fig. 307.2
 Limits of Protruding Objects

Acceptable Is there is a continuous route at least 36-inch around all obstacles or protruding objects such as fire extinguishers, aesthetic displays, shelving, light fixtures, water fountains, etc?

Acceptable Does this path not reduce to less than 32 inches for no more than 24 inches maximum?

Note: These narrower portions of the route must be positioned at least 48 inches apart.

Protruding Objects (Continued)

Parking

Parking II

Parking Accessible parking spaces should be identified by size, access aisle and signage.

Acceptable In areas where parking is provided for residents or guests of residents, at least 2% of the spaces are accessible. 8 spaces

Defective Of the accessible spaces, is at least one a van accessible space?*

[208.2.4]
 For every 6 or fraction of 6 accessible parking spaces required, at least one must be a van accessible space. None - two required. These must be one the first floor due to height limitations on higher floors.

In areas where parking is provided for the public, there are an adequate number of accessible spaces provided as required by the ADA (see table).

2010 Standards (2015)

Total Number of Parking Spaces Provided in Parking Structure (see 502.2.1)	Column A) Minimum Number of Accessible Parking Spaces (see 502.2)	Column B) Minimum Number of Van Accessible Parking Spaces (see 502.2.6)
1 to 25	1	1
26 to 50	2	1
51 to 75	3	1
76 to 100	4	1
101 to 150	5	1
151 to 200	6	1
201 to 300	7	2
301 to 400	8	2
401 to 500	9	2
500 to 1000	2% of total parking spaces, rounded up	1% of total parking spaces, rounded up
More than 1000	2% of total parking spaces, rounded up	1% of total parking spaces, rounded up

*Note: For all entries, 1% cannot be less than 1 space.

Are accessible spaces at least 8 feet wide with an access aisle at least 5 feet wide?
 [502.2, 502.3] 267 only 11' total. 266 access lane blocked by motorcycle

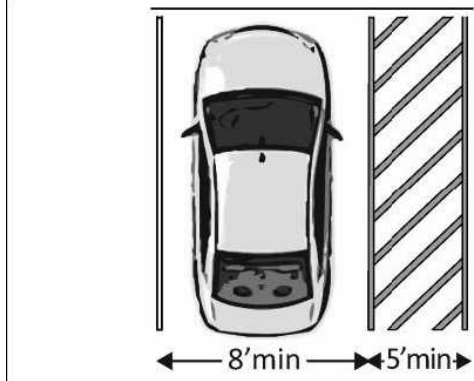

Note: Two spaces may share an access aisle. Check state/local requirements; some specify that each space have its own aisle

Parking (Continued)

Defective Is the van accessible space:
 At least 11 feet wide with an access aisle at least 5 feet wide?
 Or
 At least 8 feet wide with an access aisle at least 8 feet wide?
 [502.2] None

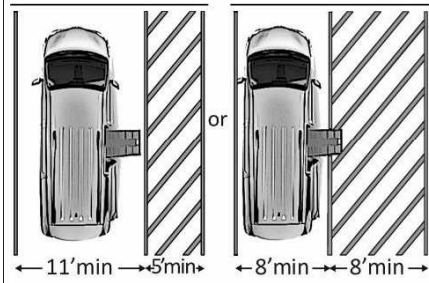

Marginal Is at least 98 inches of vertical clearance provided for the van accessible space?
 [502.5] Only on first floor. Van space must be on 1st floor. Add another space with adequate unloading area on the passenger side.

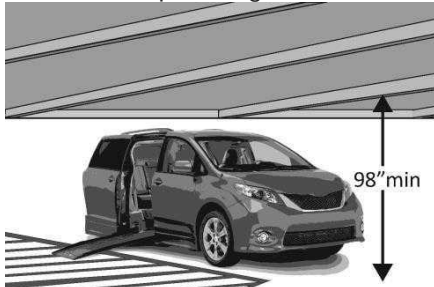

Acceptable Are the access aisles marked so as to discourage parking in them?
 [502.3.3]

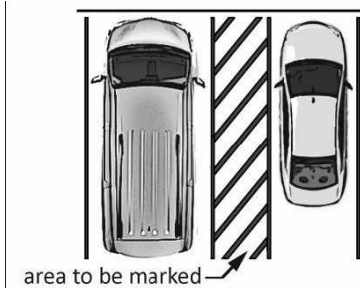

Acceptable Is the slope of the accessible parking spaces and access aisles no steeper than 1:48 in all directions?
 Acceptable Do the access aisles adjoin an accessible route?
 [502.3]



Acceptable Are accessible spaces identified with a sign that includes the International Symbol of Accessibility?

Parking (Continued)

Not Present Is the bottom of the sign at least 60 inches above the ground?
[502.6] Most are on floor. Add signs. Van accessible signs required for both van spaces.



Defective Are there signs reading "van accessible" at van accessible spaces?
[502.6]
no

Note: The International Symbol of Accessibility is not required on the ground.

Acceptable Of the total parking spaces, are the accessible spaces located on the closest accessible route to the accessible entrance(s)?
[208.3.1]

Note: If parking serves multiple entrances, accessible parking should be dispersed.

Parking (Continued)

Entry

Entry

- Acceptable Is the main entrance accessible?
- Acceptable Is the clear opening width of the accessible entrance door at least 32 inches, between the face of the door and the stop, when the door is open 90 degrees?
 [404.2.3]

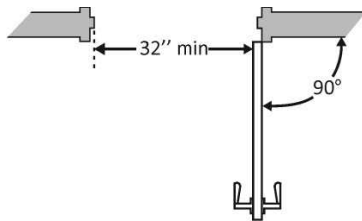

- Acceptable If there is a front approach to the pull side of the door, is there at least 18 inches of maneuvering clearance beyond the latch side plus at least 60 inches clear depth?
 Note: See 2010 Standards 404.2.4 for maneuvering clearance requirements on the push side of the door and side approaches to the pull side of the door

- Acceptable On both sides of the door, is the ground or floor surface of the maneuvering clearance level (no steeper than 1:48)?
 [404.2.4]

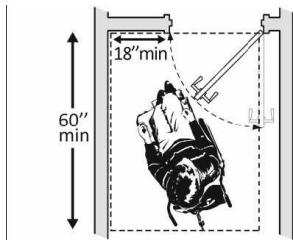

- Acceptable Is the threshold vertical is it no more than 1/2 inch high?
 Note: The first inch of the or inch threshold may be vertical; the rest must be beveled.
- Acceptable Is the door equipped with hardware that is operable with one hand and does not require tight grasping, pinching or twisting of the wrist?

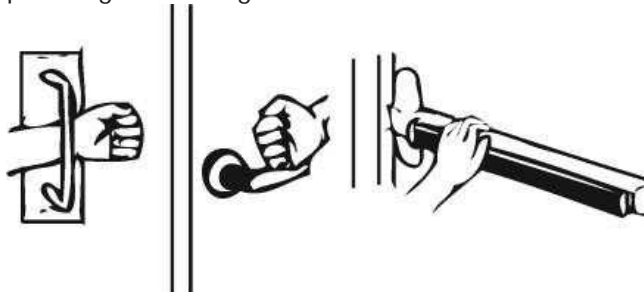

- Acceptable Door handle?

Entry (Continued)

Acceptable Are the operable parts of the door hardware no less than 34 inches and no greater than 48 inches above the floor or ground surface?
 [404.2.7]

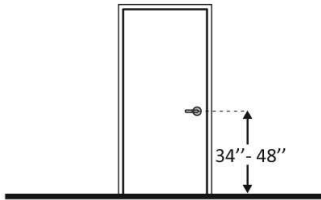

Defective If the door has a closer, does it take at least 5 seconds to close from an open position of 90 degrees to a position of 12 degrees from the latch?
 [404.2.8]

Closes too fast

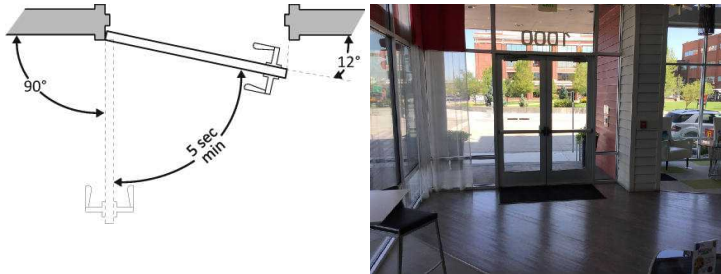

Acceptable If provided at the building entrance, are carpets or mats no higher than 1/2 inch thick?
 [302.2]



Acceptable Are edges of carpets or mats securely attached to minimize tripping hazards?
 [302.2]



Entry (Continued)

Mailbox Kiosks

Mailbox Kiosks

In buildings with elevators, are the operable parts of all mailboxes are within the following acceptable reach ranges:
Acceptable Between 15 and 48 inches with 30 x 48 inches of clear floor space positioned for a forward approach;
 or
 Between 9 and 54 inches with 30 x 48 inches of clear floor space positioned for a side parallel
 approach.

Mailbox Kiosks (Continued)

Common Areas

Common Spaces

Entrance

Acceptable Is the main entrance accessible?

Acceptable Is the clear opening width of the accessible entrance door at least 32 inches, between the face of the door and the stop, when the door is open 90 degrees?
 [404.2.3]

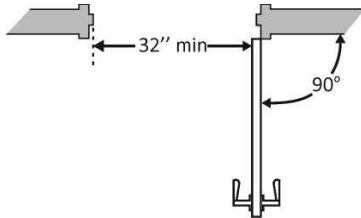

Acceptable If there is a front approach to the pull side of the door, is there at least 18 inches of maneuvering clearance beyond the latch side plus at least 60 inches clear depth?

Note: See 2010 Standards 404.2.4 for maneuvering clearance requirements on the push side of the door and side approaches to the pull side of the door

Acceptable On both sides of the door, is the ground or floor surface of the maneuvering clearance level (no steeper than 1:48)?
 [404.2.4]

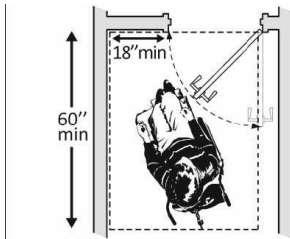

Acceptable Is the threshold vertical is it no more than 1/2 inch high?

Note: The first 1/4 inch of the 1/2 or 3/4 inch threshold may be vertical; the rest must be beveled.

Acceptable Is the door equipped with hardware that is operable with one hand and does not require tight grasping, pinching or twisting of the wrist?

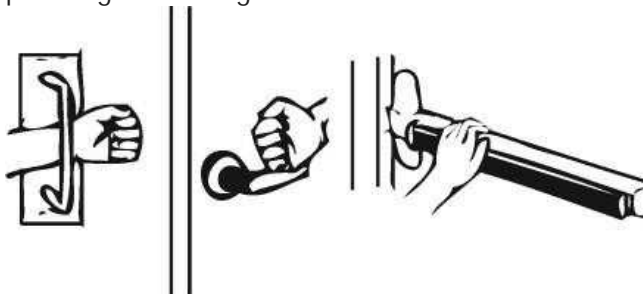

Acceptable Door handle?

Common Areas (Continued)

Acceptable Are the operable parts of the door hardware no less than 34 inches and no greater than 48 inches above the floor or ground surface?
 [404.2.7]

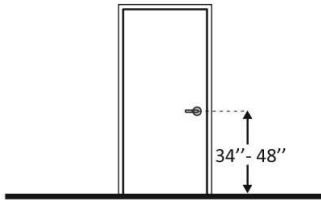

Defective If the door has a closer, does it take at least 5 seconds to close from an open position of 90 degrees to a position of 12 degrees from the latch?
 [404.2.8]

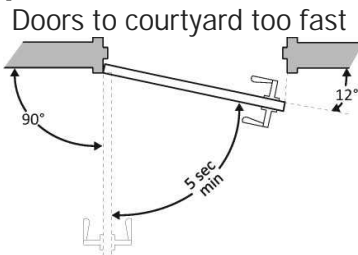

Acceptable If provided at the building entrance, are carpets or mats no higher than 1/2 inch thick?
 [302.2]



Acceptable Are edges of carpets or mats securely attached to minimize tripping hazards?
 [302.2]

Defective Is there an accessible route leading to at least one of each type of feature within each common use area. Examples include:
 Fitness equipment within fitness centers
 Laundry machines and folding tables within laundry rooms
 Pool tables and games within clubhouses
 Access lanes too narrow to TV room. 36 min required - move couch.

Common Areas (Continued)

Is there an accessible route leading to at least one of each type of featur... (continued)



Common Areas (Continued)

Alarms

Alarms

Fire Alarm Systems

Acceptable If there are fire alarm systems, do they have both flashing lights and audible signals? [702.1]



Alarm Locations If the building has an audible fire alarm system, do each of the following rooms in the hotel have a visual alarm strobe light mounted on the wall at 80" above the floor to alert deaf persons about emergency situations? [ADA Stds. 4.1.3(14)]

Lobby/front desk Public corridors Ballrooms and meeting rooms Public and employee restrooms

Alarms (Continued)

Interior Doors

Interior Doors to classrooms, medical exam rooms, conference rooms, etc.

Interior doors

Access ADA Compliant: No Closes too fast, requires more than 5 lbs pressure to open - south elevator room, locker room and elevator room doors, fitness room balcony close too fast.

Acceptable Is the door opening width at least 32 inches clear, between the face of the door and the stop, when the door is open 90 degrees?

[404.2.3]

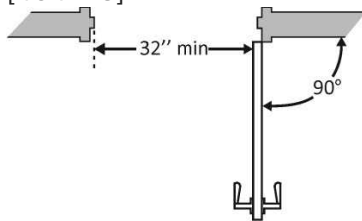

Acceptable If there is a front approach to the pull side of the door, is there at least 18 inches of maneuvering clearance beyond the latch side plus at least 60 inches clear depth?

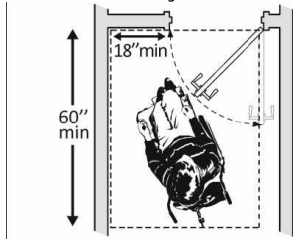

Note: See 2010 Standards 404.2.4 for maneuvering clearance requirements on the push side of the door and side approaches to the pull side of the door.

Acceptable On both sides of the door, is the floor surface of the maneuvering clearance level (no steeper than 1:48)?

[404.2.4]

Acceptable If the threshold is vertical is it no more than inch high?

Note: The first inch of the or inch threshold may be vertical; the rest must be beveled.

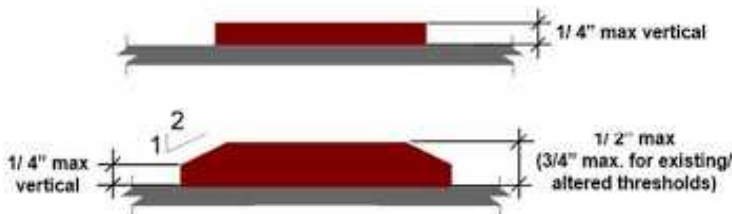

Note: vertical edge must be located below bevel, not above

Acceptable Is the door equipped with hardware that is operable with one hand and does not require tight grasping, pinching or twisting of the wrist?

Acceptable Door handle?

Interior Doors (Continued)

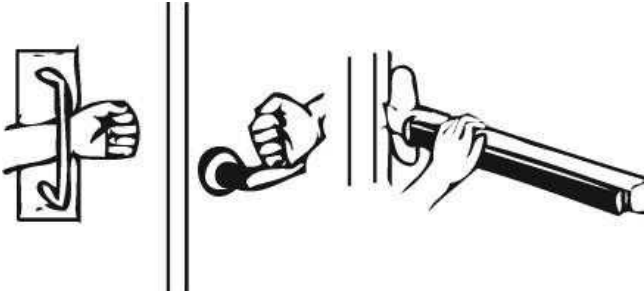

Acceptable Are the operable parts of the hardware no less than 34 inches and no greater than 48 inches above the floor?
 [404.2.7]

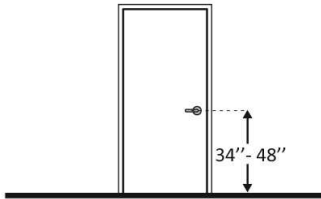

Rooms and Spaces stores, supermarkets, libraries, etc.

Acceptable Stable, slip resistant



Acceptable Carpet

Acceptable Carpets, mats secure

Controls light switches, security and intercom systems, emergency/alarm boxes, etc.

Acceptable Clear floor space

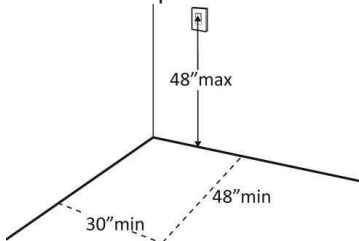

Interior Doors (Continued)

Ramps

Ramps

Ramps If any portion of the accessible route is steeper than 1:20, it should be treated as a ramp.

Acceptable If there is a ramp, is it at least 36 inches wide?
 [405.5]

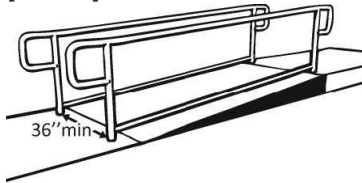

Note: If there are handrails, measure between the handrails.

Acceptable Is the surface stable, firm and slip resistant?
 [405.4]

Acceptable For each section of the ramp, is the running slope no greater than 1:12, i.e. for every inch of height change there are at least 12 inches of ramp run?
 [405.2]

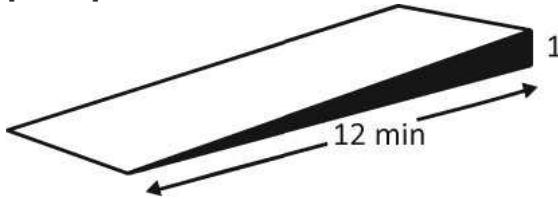

Note: Rises no greater than 3 inches with a slope no steeper than 1:8 and rises no greater than 6 inches with a slope no steeper than 1:10 are permitted when due to space limitations.

Acceptable Is there a level landing that is at least 60 inches long and at least as wide as the ramp?
 At the top of the ramp?

Acceptable Is there a level landing that is at least 60 inches long and at least as wide as the ramp?
 At the bottom of the ramp?
 [405.7.2, 405.7.3]

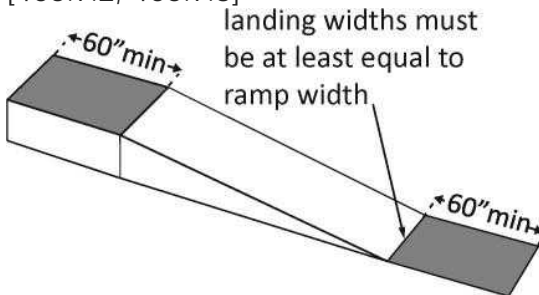

Acceptable Is there a level landing where the ramp changes direction that is at least 60 x 60 inches?
 [405.7.4]

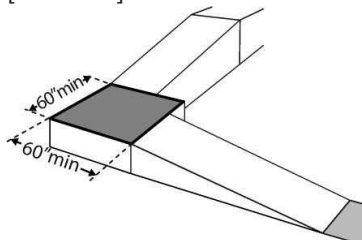

Ramps (Continued)

Acceptable If the ramp has a rise higher than 6 inches are there handrails on both sides?
 [405.8]

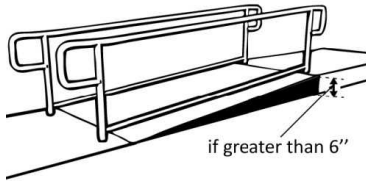

Note: Curb ramps are not required to have handrails

Acceptable Is the top of the handrail gripping surface no less than 34 inches and no greater than 38 inches above the ramp surface?
 [505.4]

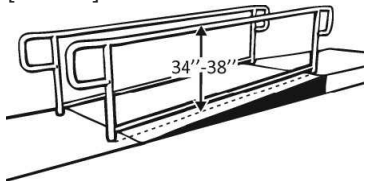

Acceptable Is the handrail gripping surface continuous and not obstructed along the top or sides?
 [505.3]

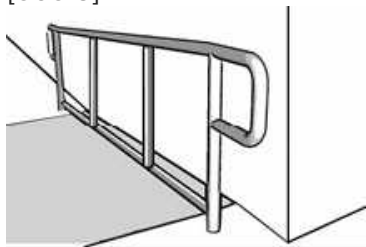

Acceptable If there are obstructions, is the bottom of the gripping surface obstructed no more than 20%?
 [505.6]

Acceptable If the handrail gripping surface is circular, is it no less than 1 inches and no greater than 2 inches in diameter?
 [505.7.1]

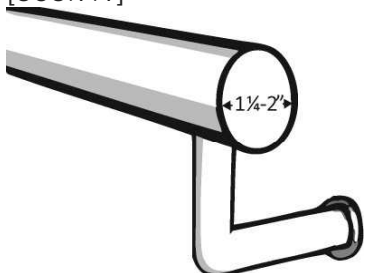

If the handrail gripping surface is non-circular:

Ramps (Continued)

Acceptable Is the perimeter no less than 4 inches and no greater than 6 inches?

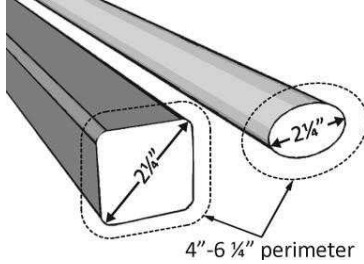

Acceptable Is the cross section no greater than 2 inches?
 [505.7.2]

Does the handrail:

Acceptable Extend at least 12 inches horizontally beyond the top and bottom of the ramp?

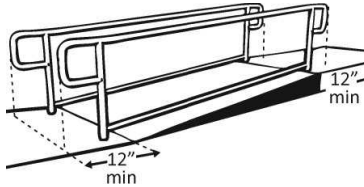

Note: If a 12 inch extension would be hazardous (in circulation path), it is not required.
 To prevent wheelchair casters and crutch tips from falling off:

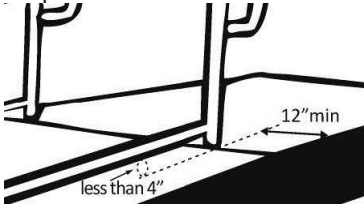

Acceptable Or
 Is there a curb or barrier that prevents the passage of a 4-inch diameter sphere?
 [405.9.1, 405.9.2]

Ramps (Continued)

Elevators

Elevators Full Size & LULA (limited use, limited application) LULA elevators are often used in alterations.

South ADA Elevator

Acceptable If there is a full size elevator, are the call buttons no higher than 54 inches above the floor?
 [407.2.1.1]

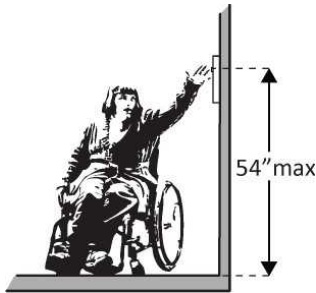

Acceptable If there is a full size elevator, does the sliding door reopen automatically when obstructed by an object or person?*

[407.3.3]

If there is a full size elevator:

Acceptable Is the interior at least 54 inches deep by at least 36 inches wide with at least 16 sq. ft. of clear floor area?

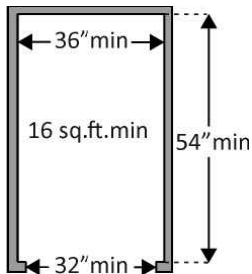

Acceptable Is the door opening width at least 32 inches?
 [407.4.1 Exception]

If there is a full size elevator, are the in-car controls:

Acceptable No less than 15 inches and no greater 48 inches above the floor?

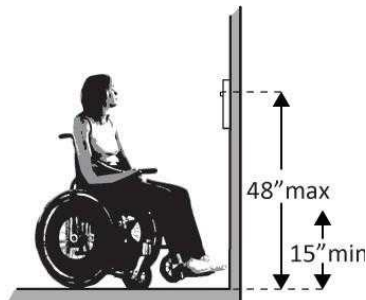

If there is a full size elevator:

Elevators (Continued)

- Acceptable Are the car control buttons designated with raised characters?
- Acceptable Are the car control buttons designated with Braille?
 [407.4.7.1, 703.2]

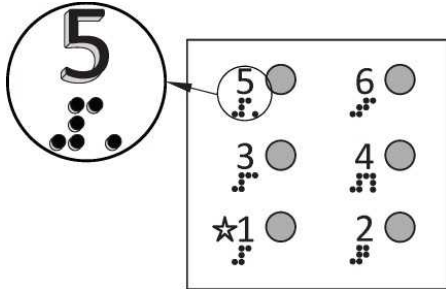

- Acceptable If there is a full size elevator, are there audible signals which sound as the car passes or is about to stop at a floor?
 [407.4.8]

If there is a full size elevator:

- Acceptable Is there a sign on both door jambs at every floor identifying the floor?

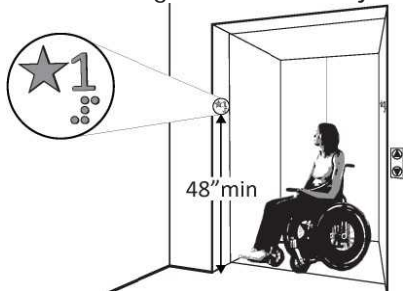

- Acceptable Is there a tactile star on both jambs at the main entry level?
 - Acceptable Do text characters contrast with their backgrounds?
 - Acceptable Are text characters raised?
 - Acceptable Is there Braille?
 - Acceptable Is the sign mounted between 48 inches to the baseline of the lowest character and 60 inches to the baseline of the highest character above the floor?*
- [407.2.3, 408.2.3]

Elevators (Continued)

Elevators Full Size & LULA (limited use, limited application) LULA elevators are often used in alterations.

North ADA Elevator

Acceptable If there is a full size elevator, are the call buttons no higher than 54 inches above the floor?
 [407.2.1.1]

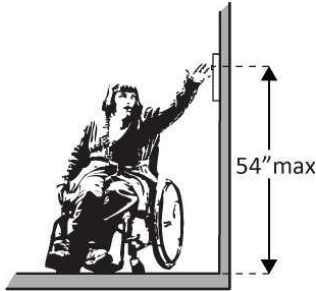

Acceptable If there is a full size elevator, does the sliding door reopen automatically when obstructed by an object or person?*

[407.3.3]

If there is a full size elevator:

Acceptable Is the interior at least 54 inches deep by at least 36 inches wide with at least 16 sq. ft. of clear floor area?

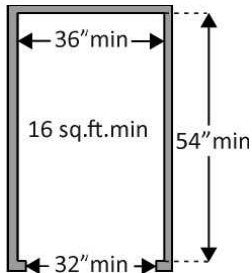

Acceptable Is the door opening width at least 32 inches?
 [407.4.1 Exception]

If there is a full size elevator, are the in-car controls:

Acceptable No less than 15 inches and no greater 48 inches above the floor?

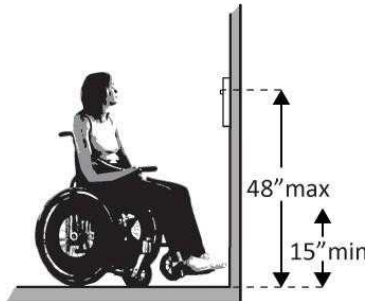

Elevators (Continued)

Acceptable OR
 Up to 54 inches above the floor for a parallel approach?
 [408.4.6, 407.4.6.1]

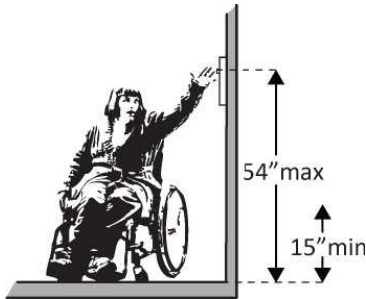

If there is a full size elevator:

Acceptable Are the car control buttons designated with raised characters?

Acceptable Are the car control buttons designated with Braille?
 [407.4.7.1, 703.2]

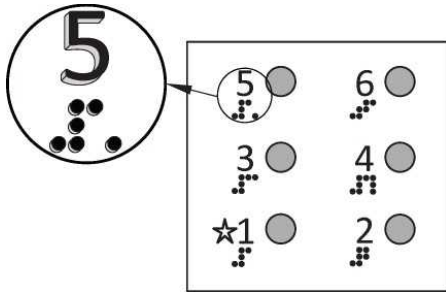

Acceptable If there is a full size elevator, are there audible signals which sound as the car passes or is about to stop at a floor?
 [407.4.8]

If there is a full size elevator:

Acceptable Is there a sign on both door jambs at every floor identifying the floor?

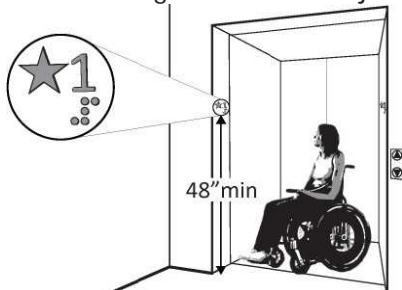

Acceptable Is there a tactile star on both jambs at the main entry level?

Acceptable Do text characters contrast with their backgrounds?

Acceptable Are text characters raised?

Acceptable Is there Braille?

Acceptable Is the sign mounted between 48 inches to the baseline of the lowest character and 60 inches to the baseline of the highest character above the floor?*

[407.2.3, 408.2.3]



Colorado Inspection Services, LLC

Prepared for:
1 Main St

Elevators (Continued)

Is the sign mounted between 48 inches to the baseline of the lowest charact... (continued)



Elevators (Continued)

Stairs

Stairs

- Acceptable Do the stairs have closed risers so a crutch or cane cannot slip through the open space between the stair risers and people will not lose their balance as they climb the stairs? [ADA Stds. 4.9]
- Acceptable Are there handrails on both sides of the stair at a uniform height of 34"-38" above the front edge of the step? [ADA Stds. 4.9]
- Acceptable Do the handrails extend horizontally at the top and bottom of each stair section to give persons who have difficulty using the stairs a stable gripping location before ascending or descending? [ADA Stds. 4.9]

Stairs (Continued)

Restrooms

Location 1st floor

Accessible route

Acceptable If toilet rooms are available to the public, is at least one toilet room accessible? (Either one for each sex, or one unisex.)

Note: If toilet rooms are chiefly for children, e.g., in elementary schools and day care centers, use the childrens specifications in Toilets - 604.1, 604.8, 604.9, 609.4 and Lavatories and Sinks 606.2.

Accessible Route

Acceptable Is there an accessible route to the accessible toilet room?
 [206.2.4]

Signs at Toilet Rooms

Acceptable Do text characters contrast with their backgrounds?
 [703.5]

Acceptable Are text characters raised?
 [703.2]

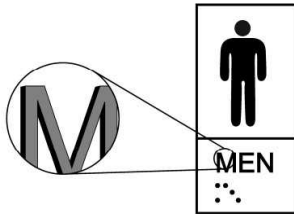

Acceptable Is there Braille?
 [703.3]

Is the sign mounted:

Acceptable On the wall on the latch side of the door?
 [703.4.2]

Note: Signs are permitted on the push side of doors with closers and without hold-open devices.

Acceptable With clear floor space beyond the arc of the door swing between the closed position and 45-degree open position, at least 18 x 18 inches centered on the tactile characters? *

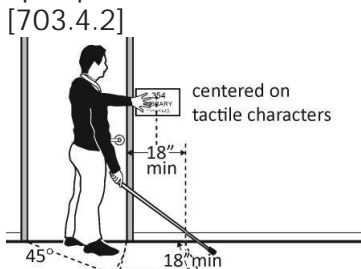

Acceptable So the baseline of the lowest character is at least 48 inches above the floor and the baseline of the highest character is no more than 60 above floor

Restrooms (Continued)

So the baseline of the lowest character is at least 48 inches above the flo... (continued)

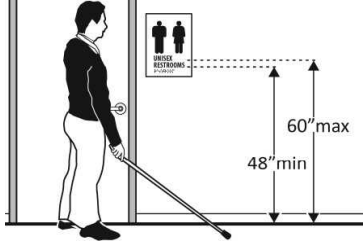

Note: If the sign is at double doors with one active leaf, the sign should be on the inactive leaf; if both leaves are active, the sign should be on the wall to the right of the right leaf.

Entrance

Acceptable Is the door opening width at least 32 inches clear, between the face of the door and the stop, when the door is open 90 degrees?
 [404.2.3]

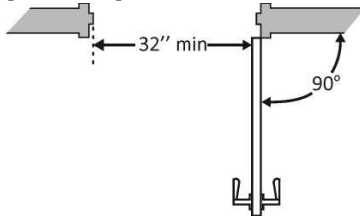

Acceptable If there is a front approach to the pull side of the door is there at least 18 inches of maneuvering clearance beyond the latch side plus 60 inches clear depth?

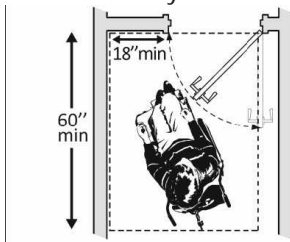

Note: See 2010 Standards 404.2.4 for maneuvering clearance requirements on the push side of the door and side approaches to the pull side of the door

Acceptable On both sides of the door, is the floor surface of the maneuvering clearance level (no steeper than 1:48)?
 [404.2.4]

Acceptable Is the threshold no more than 1/4 inch high?

Note: The first 1/4 inch of the 1/2 or 3/4 inch threshold may be vertical; the rest must be beveled.

Acceptable Is the door equipped with hardware that is operable with one hand and does not require tight grasping, pinching or twisting of the wrist?

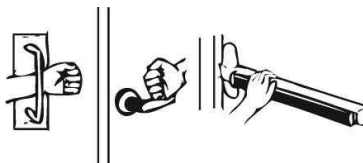

Acceptable Door handle?

Restrooms (Continued)

Defective Lock (if provided)?
 [404.2.7]
 Lock requires grasp



Acceptable Are the operable parts of the door hardware mounted no less than 34 inches and no greater than 48 inches above the floor?
 [404.2.7]

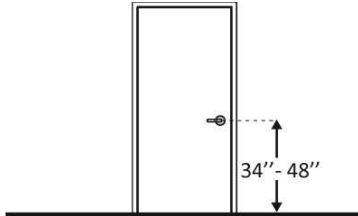

Defective Can the door be opened easily (5 pounds maximum force)?
 [404.2.9]

Note: You can use a pressure gauge or fish scale to measure force. If you do not have one you will need to judge whether the door is easy to open. no

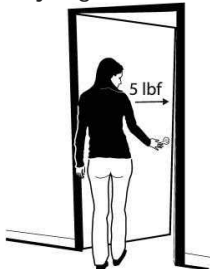

Defective If the door has a closer, does it take at least 5 seconds to close from an open position of 90 degrees to a position of 12 degrees from the latch?
 [404.2.8.1] closes too fast

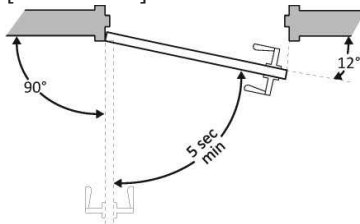

In the Toilet Room

Acceptable Is there a clear path to at least one of each type of fixture, e.g. lavatory, hand dryer, etc., that is at least 36 inches wide?
 [403.5.1]

Restrooms (Continued)

Is there a clear path to at least one of each type of fixture, e.g. lavator... (continued)



Acceptable

Is there clear floor space available for a person in a wheelchair to turn around, i.e. a circle at least 60 inches in diameter or a T-shaped space within a 60-inch square?

[603.2.1]

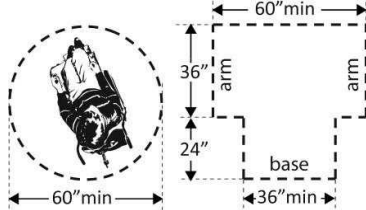

Acceptable

In a single user toilet room if the door swings in and over a clear floor space at an accessible fixture, is there a clear floor space at least 30 x 48 inches beyond the swing of the door?

[603.2.3 Exception 2]

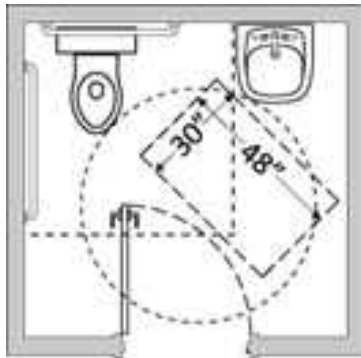

Acceptable

If the mirror is over a lavatory or countertop, is the bottom edge of the reflecting surface no higher than 40 inches above the floor?

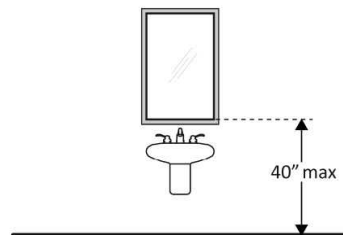

Lavatories The 2010 Standards refer to sinks in toilet rooms as lavatories.

Acceptable

Does at least one lavatory have a clear floor space for a forward approach at least 30 inches wide and 48 inches long?

[606.2]

Restrooms (Continued)

Does at least one lavatory have a clear floor space for a forward approach ... (continued)

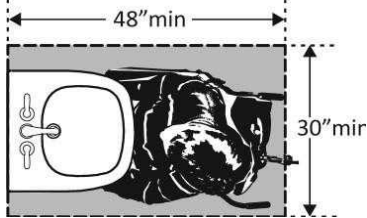

Acceptable Do no less than 17 inches and no greater than 25 inches of the clear floor space extend under the lavatory so that a person using a wheelchair can get close enough to reach the faucet?
 [306.2]

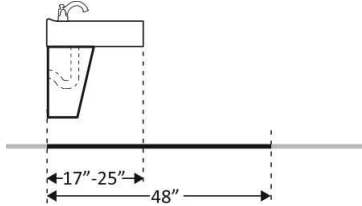

Acceptable Is the front of the lavatory or counter surface, whichever is higher, no more than 34 inches above the floor?
 [606.3]

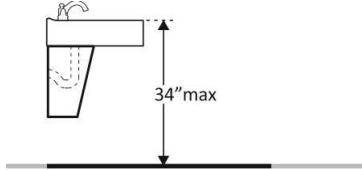

Acceptable Is there at least 27 inches clearance from the floor to the bottom of the lavatory that extends at least 8 inches under the lavatory for knee clearance?
 [306.3.3]

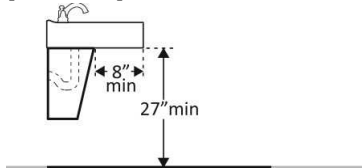

Acceptable Is there toe clearance at least 9 inches high?
 [306.3.3]

Note: Space extending greater than 6 inches beyond the available toe clearance at 9 inches above the floor is not considered toe clearance.

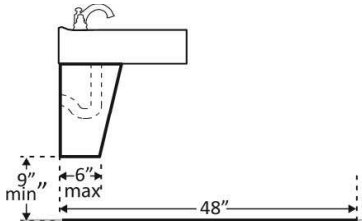

Restrooms (Continued)

Acceptable Are pipes below the lavatory insulated or otherwise configured to protect against contact?
 [606.5]

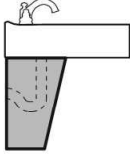

Acceptable Can the faucet be operated without tight grasping, pinching, or twisting of the wrist?

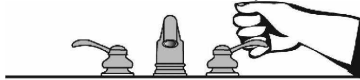

Acceptable Is the force required to activate the faucet no greater than 5 pounds?
 [606.4]

Soap Dispensers and Hand Dryers (2010 Standards 603)

Are the operable parts of the soap dispenser within one of the following reach ranges:

Are the operable parts of the hand dryer or towel dispenser within one of the following reach ranges:

Acceptable Can the operable parts of the hand dryer or towel dispenser be operated without tight grasping, pinching or twisting of the wrist?

Acceptable Is the force required to activate the hand dryer or towel dispenser no greater than 5 pounds?
 [309.4]

Water Closets in Single-User Toilet Rooms and Compartments (Stalls) The 2010 Standards refer to toilets as water closets.

Acceptable Is the centerline of the water closet no less than 16 inches and no greater than 18 inches from the side wall or partition?
 [604.2]

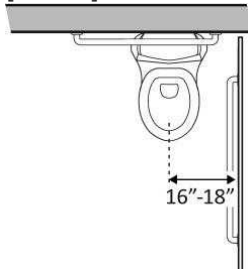

Acceptable Is clearance provided around the water closet measuring at least 60 inches from the side wall and at least 56 inches from the rear wall?*

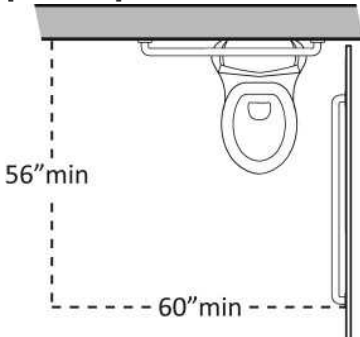

Restrooms (Continued)

If constructed before 3/15/12, clearances around water closets in single user toilet rooms can be 48 inches wide by 66 inches long or 48 inches wide by 56 inches long (depending on the approach to the water closet, see 1991 Standards Figure 28) and the lavatory may overlap that clearance if the door to the room does not swing into the required clearances at fixtures (such as lavatories, water closet and urinals) and the edge of the lavatory is at least 18 inches from the centerline of the water closet

Acceptable Is the height of the water closet no less than 17 inches and no greater than 19 inches above the floor measured to the top of the seat?

[604.4]

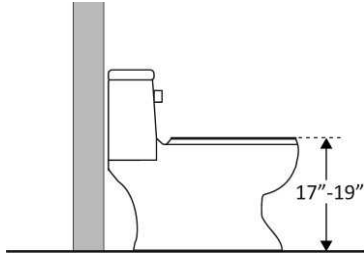

Grab bars

Acceptable Is there a grab bar at least 42 inches long on the side wall?

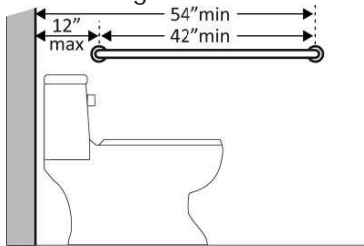

Acceptable Is it located no more than 12 inches from the rear wall?

Acceptable Does it extend at least 54 inches from the rear wall?

[604.5.1]

Acceptable Is it mounted no less than 33 inches and no greater than 36 inches above the floor to the top of the gripping surface?

[609.4]

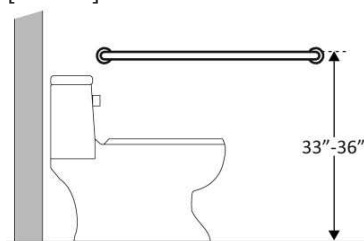

Acceptable Is the space between the grab bar and the wall 1 1/2 inch?

If constructed before 3/15/2012 grab bars do not need to be relocated; there are no space requirements above and below grab bars in the 1991 Standards

Acceptable If the flush control is hand operated, can it be operated with one hand and without tight grasping, pinching, or twisting of the wrist?

Restrooms (Continued)

If the flush control is hand operated, can it be operated with one hand and... (continued)

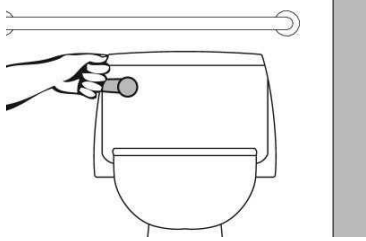

Acceptable Is the force required to activate the flush control no greater than 5 pounds?
 [605.4]

Acceptable Is the toilet paper dispenser located no less than 7 inches and no greater than 9 inches from the front of the water closet to the centerline of the dispenser?*

Is the outlet of the dispenser:

Acceptable Located no less than 15 inches and no greater than 48 inches above the floor?

Acceptable Not located behind grab bars?
 [604.7]

Acceptable Does the dispenser allow continuous paper flow?
 [604.7]

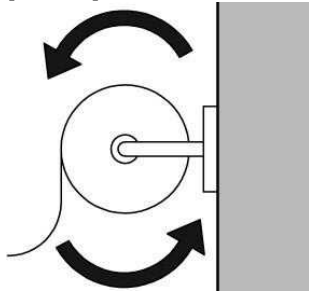

If constructed before 3/15/2012 dispenser does not need to be relocated if it is within reach from the water closet seat; the 1991 Standards do not specify distance from the front of the water closet

Toilet Compartments (Stalls)

Note: See 2010 Standards 604.8.1.2 Doors for maneuvering clearance requirements on the push side of the door and side approaches to the pull side of the door

If constructed before 3/15/2012 door pulls do not need to be added; door pulls are not required in the 1991 Standards

Urinals Height and Depth. 605.2

Restrooms (Continued)

Location 2nd floor

Accessible route

Acceptable If toilet rooms are available to the public, is at least one toilet room accessible? (Either one for each sex, or one unisex.)

Note: If toilet rooms are chiefly for children, e.g., in elementary schools and day care centers, use the childrens specifications in Toilets - 604.1, 604.8, 604.9, 609.4 and Lavatories and Sinks 606.2.

Accessible Route

Acceptable Is there an accessible route to the accessible toilet room?
 [206.2.4]

Signs at Toilet Rooms

Acceptable Do text characters contrast with their backgrounds?
 [703.5]

Acceptable Are text characters raised?
 [703.2]

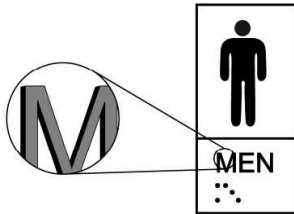

Acceptable Is there Braille?
 [703.3]

Is the sign mounted:

Acceptable On the wall on the latch side of the door?
 [703.4.2]

Note: Signs are permitted on the push side of doors with closers and without hold-open devices.

Acceptable With clear floor space beyond the arc of the door swing between the closed position and 45-degree open position, at least 18 x 18 inches centered on the tactile characters? *
 [703.4.2]

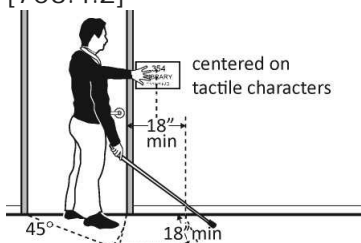

Acceptable So the baseline of the lowest character is at least 48 inches above the floor and the baseline of the highest character is no more than 60 above floor

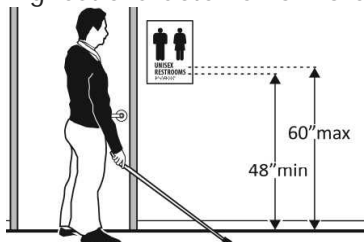

Note: If the sign is at double doors with one active leaf, the sign should be on the inactive leaf; if both leaves are active, the sign should be on the wall to the right of the right leaf.

Restrooms (Continued)

Entrance

Acceptable Is the door opening width at least 32 inches clear, between the face of the door and the stop, when the door is open 90 degrees?

[404.2.3]

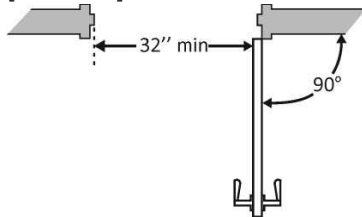

Note: See 2010 Standards 404.2.4 for maneuvering clearance requirements on the push side of the door and side approaches to the pull side of the door

Acceptable On both sides of the door, is the floor surface of the maneuvering clearance level (no steeper than 1:48)?

[404.2.4]

Acceptable Is the threshold no more than 1/4 inch high?

Note: The first 1/4 inch of the 1/2 or 3/4 inch threshold may be vertical; the rest must be beveled.

Acceptable Is the door equipped with hardware that is operable with one hand and does not require tight grasping, pinching or twisting of the wrist?

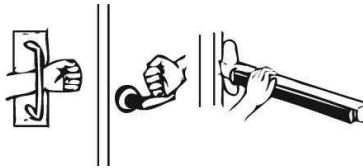

Acceptable Door handle?

Acceptable Lock (if provided)?

[404.2.7]

Acceptable Are the operable parts of the door hardware mounted no less than 34 inches and no greater than 48 inches above the floor?

[404.2.7]

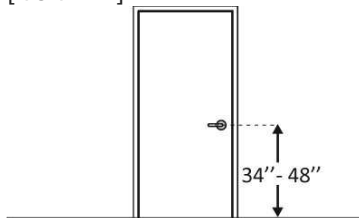

Defective Can the door be opened easily (5 pounds maximum force)?

[404.2.9]

Note: You can use a pressure gauge or fish scale to measure force. If you do not have one you will need to judge whether the door is easy to open. Womens room greater than 5 lbs required

Restrooms (Continued)

Can the door be opened easily (5 pounds maximum force)? [404.2.9] Note:... (continued)

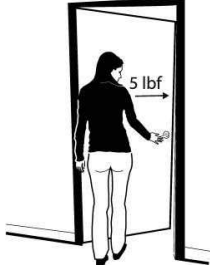

Defective If the door has a closer, does it take at least 5 seconds to close from an open position of 90 degrees to a position of 12 degrees from the latch?
 [404.2.8.1] Womens door closes too fast.

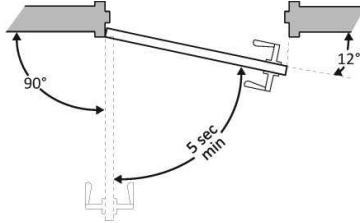

In the Toilet Room

Acceptable Is there a clear path to at least one of each type of fixture, e.g. lavatory, hand dryer, etc., that is at least 36 inches wide?
 [403.5.1]



Acceptable Is there clear floor space available for a person in a wheelchair to turn around, i.e. a circle at least 60 inches in diameter or a T-shaped space within a 60-inch square?
 [603.2.1]

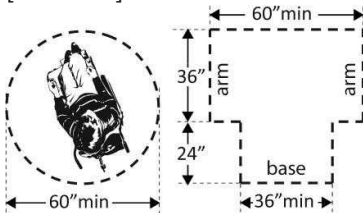

Acceptable In a single user toilet room if the door swings in and over a clear floor space at an accessible fixture, is there a clear floor space at least 30 x 48 inches beyond the swing of the door?
 [603.2.3 Exception 2]

Restrooms (Continued)

In a single user toilet room if the door swings in and over a clear floor s... (continued)

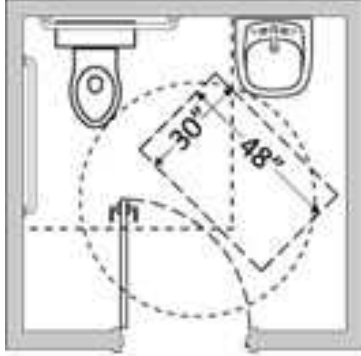

Acceptable If the mirror is over a lavatory or countertop, is the bottom edge of the reflecting surface no higher than 40 inches above the floor?

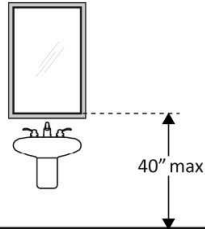

Lavatories The 2010 Standards refer to sinks in toilet rooms as lavatories.

Acceptable Does at least one lavatory have a clear floor space for a forward approach at least 30 inches wide and 48 inches long?
 [606.2]

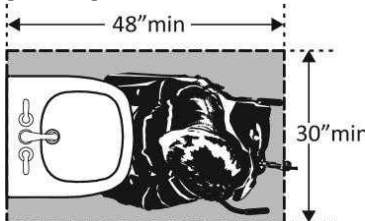

Acceptable Do no less than 17 inches and no greater than 25 inches of the clear floor space extend under the lavatory so that a person using a wheelchair can get close enough to reach the faucet?
 [306.2]

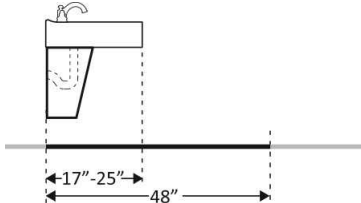

Acceptable Is the front of the lavatory or counter surface, whichever is higher, no more than 34 inches above the floor?
 [606.3]

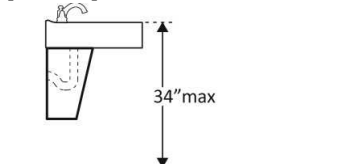

Restrooms (Continued)

Acceptable Is there at least 27 inches clearance from the floor to the bottom of the lavatory that extends at least 8 inches under the lavatory for knee clearance?
 [306.3.3]

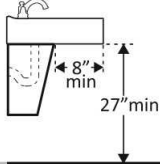

Acceptable Is there toe clearance at least 9 inches high?
 [306.3.3]
 Note: Space extending greater than 6 inches beyond the available toe clearance at 9 inches above the floor is not considered toe clearance.

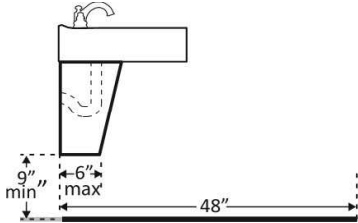

Acceptable Are pipes below the lavatory insulated or otherwise configured to protect against contact?
 [606.5]

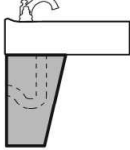

Acceptable Can the faucet be operated without tight grasping, pinching, or twisting of the wrist?

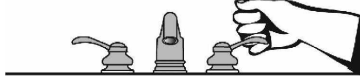

Acceptable Is the force required to activate the faucet no greater than 5 pounds?
 [606.4]

Soap Dispensers and Hand Dryers (2010 Standards 603)

Are the operable parts of the soap dispenser within one of the following reach ranges:

Are the operable parts of the hand dryer or towel dispenser within one of the following reach ranges:

Acceptable Can the operable parts of the hand dryer or towel dispenser be operated without tight grasping, pinching or twisting of the wrist?

Acceptable Is the force required to activate the hand dryer or towel dispenser no greater than 5 pounds?
 [309.4]

Water Closets in Single-User Toilet Rooms and Compartments (Stalls) The 2010 Standards refer to toilets as water closets.

Restrooms (Continued)

Acceptable Is the centerline of the water closet no less than 16 inches and no greater than 18 inches from the side wall or partition?
 [604.2]

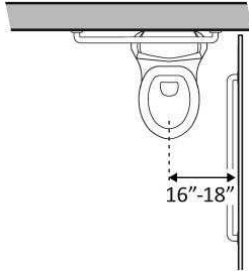

Acceptable Is clearance provided around the water closet measuring at least 60 inches from the side wall and at least 56 inches from the rear wall?*

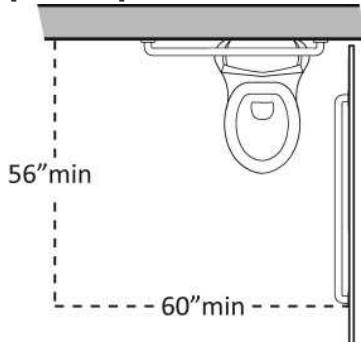

If constructed before 3/15/12, clearances around water closets in single user toilet rooms can be 48 inches wide by 66 inches long or 48 inches wide by 56 inches long (depending on the approach to the water closet, see 1991 Standards Figure 28) and the lavatory may overlap that clearance if the door to the room does not swing into the required clearances at fixtures (such as lavatories, water closet and urinals) and the edge of the lavatory is at least 18 inches from the centerline of the water closet

Acceptable Is the height of the water closet no less than 17 inches and no greater than 19 inches above the floor measured to the top of the seat?
 [604.4]

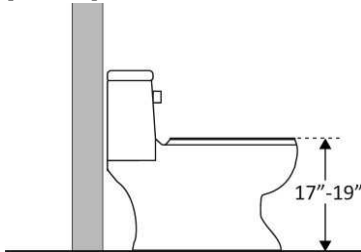

Grab bars
 Acceptable Is there a grab bar at least 42 inches long on the side wall?

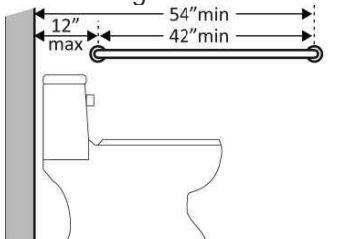

Restrooms (Continued)

Acceptable Is it located no more than 12 inches from the rear wall?

Acceptable Does it extend at least 54 inches from the rear wall?
 [604.5.1]

Acceptable Is it mounted no less than 33 inches and no greater than 36 inches above the floor to the top of the gripping surface?
 [609.4]

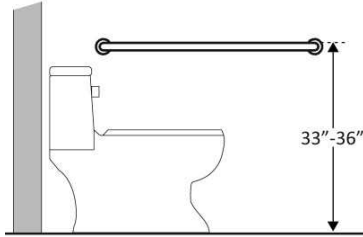

Acceptable Is there at least 12 inches clearance between the grab bar and projecting objects above?*

Acceptable Is the space between the grab bar and the wall 1 1/2 inch?

If constructed before 3/15/2012 grab bars do not need to be relocated; there are no space requirements above and below grab bars in the 1991 Standards

Acceptable If the flush control is hand operated, is the operable part located no higher than 48 inches above the floor?
 [604.6]

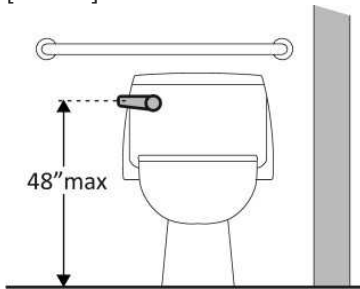

Acceptable If the flush control is hand operated, can it be operated with one hand and without tight grasping, pinching, or twisting of the wrist?

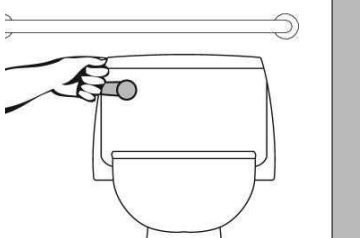

Acceptable Is the force required to activate the flush control no greater than 5 pounds?
 [605.4]

Acceptable Is the flush control on the open side of the water closet?
 [604.6]

Restrooms (Continued)

Is the flush control on the open side of the water closet? [604.6] (continued)

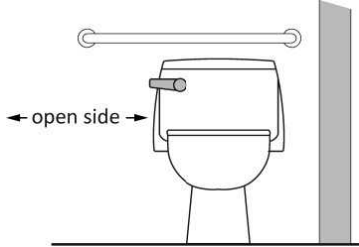

Acceptable Is the toilet paper dispenser located no less than 7 inches and no greater than 9 inches from the front of the water closet to the centerline of the dispenser?*[604.7]

Is the outlet of the dispenser:

Acceptable Located no less than 15 inches and no greater than 48 inches above the floor?

Acceptable Not located behind grab bars?
[604.7]

Acceptable Does the dispenser allow continuous paper flow?
[604.7]

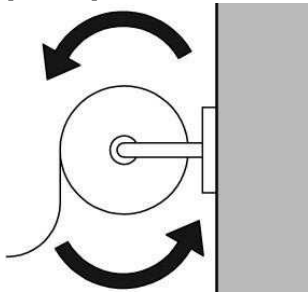

If constructed before 3/15/2012 dispenser does not need to be relocated if it is within reach from the water closet seat; the 1991 Standards do not specify distance from the front of the water closet

Toilet Compartments (Stalls)

Note: See 2010 Standards 604.8.1.2 Doors for maneuvering clearance requirements on the push side of the door and side approaches to the pull side of the door

If constructed before 3/15/2012 door pulls do not need to be added; door pulls are not required in the 1991 Standards

Urinals Height and Depth. 605.2

Restrooms (Continued)

Location Roof

Accessible route

Acceptable If toilet rooms are available to the public, is at least one toilet room accessible? (Either one for each sex, or one unisex.)

Note: If toilet rooms are chiefly for children, e.g., in elementary schools and day care centers, use the childrens specifications in Toilets - 604.1, 604.8, 604.9, 609.4 and Lavatories and Sinks 606.2.

Acceptable Are there signs at inaccessible toilet rooms that give directions to accessible toilet rooms?
 [See 2010 ADA Standards for Accessible Design 216.8]



Accessible Route

Acceptable Is there an accessible route to the accessible toilet room?
 [206.2.4]

Signs at Toilet Rooms

Acceptable Do text characters contrast with their backgrounds?
 [703.5]

Acceptable Are text characters raised?
 [703.2]

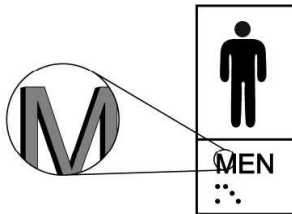

Acceptable Is there Braille?
 [703.3]

Is the sign mounted:

Acceptable On the wall on the latch side of the door?
 [703.4.2]

Note: Signs are permitted on the push side of doors with closers and without hold-open devices.

Acceptable With clear floor space beyond the arc of the door swing between the closed position and 45-degree open position, at least 18 x 18 inches centered on the tactile characters? *

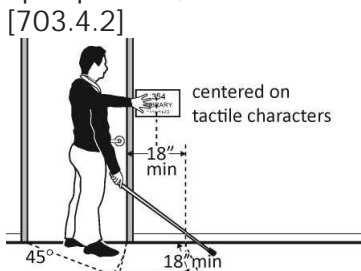

Restrooms (Continued)

Acceptable So the baseline of the lowest character is at least 48 inches above the floor and the baseline of the highest character is no more than 60 above floor

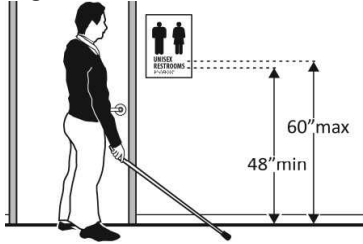

Note: If the sign is at double doors with one active leaf, the sign should be on the inactive leaf; if both leaves are active, the sign should be on the wall to the right of the right leaf.

Entrance

Acceptable Is the door opening width at least 32 inches clear, between the face of the door and the stop, when the door is open 90 degrees?

[404.2.3]

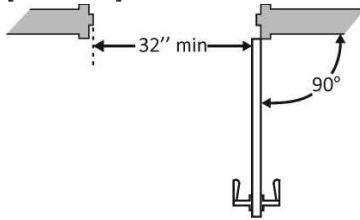

Acceptable If there is a front approach to the pull side of the door is there at least 18 inches of maneuvering clearance beyond the latch side plus 60 inches clear depth?

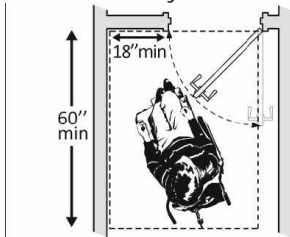

Note: See 2010 Standards 404.2.4 for maneuvering clearance requirements on the push side of the door and side approaches to the pull side of the door

Acceptable On both sides of the door, is the floor surface of the maneuvering clearance level (no steeper than 1:48)?

[404.2.4]

Acceptable Is the threshold no more than 1/4 inch high?

Note: The first 1/4 inch of the 1/2 or 3/4 inch threshold may be vertical; the rest must be beveled.

Acceptable Is the door equipped with hardware that is operable with one hand and does not require tight grasping, pinching or twisting of the wrist?

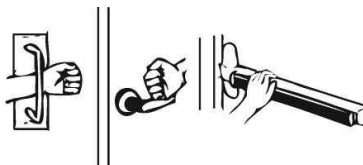

Acceptable Door handle?

Restrooms (Continued)

Defective Lock (if provided)?
 [404.2.7]
 Requires grasp



Acceptable Are the operable parts of the door hardware mounted no less than 34 inches and no greater than 48 inches above the floor?
 [404.2.7]

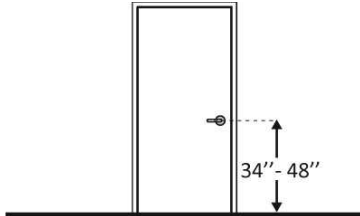

Can the door be opened easily (5 pounds maximum force)?
 [404.2.9]

Note: You can use a pressure gauge or fish scale to measure force. If you do not have one you will need to judge whether the door is easy to open. West door requires too much force.

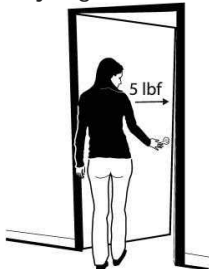

Defective If the door has a closer, does it take at least 5 seconds to close from an open position of 90 degrees to a position of 12 degrees from the latch?
 [404.2.8.1] West door closes too fast.

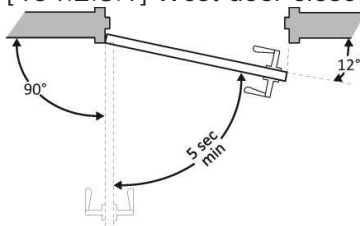

In the Toilet Room

Acceptable Is there a clear path to at least one of each type of fixture, e.g. lavatory, hand dryer, etc., that is at least 36 inches wide?
 [403.5.1]

Restrooms (Continued)

Is there a clear path to at least one of each type of fixture, e.g. lavator... (continued)



Acceptable

Is there clear floor space available for a person in a wheelchair to turn around, i.e. a circle at least 60 inches in diameter or a T-shaped space within a 60-inch square?

[603.2.1]

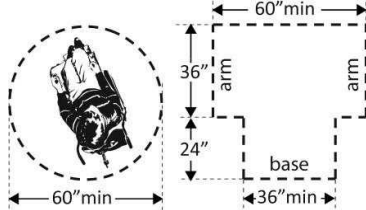

Acceptable

In a single user toilet room if the door swings in and over a clear floor space at an accessible fixture, is there a clear floor space at least 30 x 48 inches beyond the swing of the door?

[603.2.3 Exception 2]

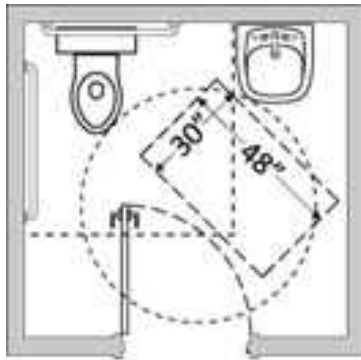

Acceptable

If the mirror is over a lavatory or countertop, is the bottom edge of the reflecting surface no higher than 40 inches above the floor?

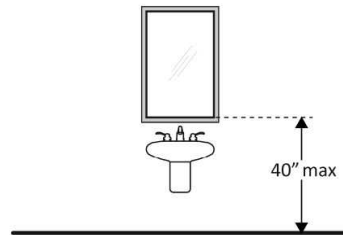

Lavatories The 2010 Standards refer to sinks in toilet rooms as lavatories.

Acceptable

Does at least one lavatory have a clear floor space for a forward approach at least 30 inches wide and 48 inches long?

[606.2]

Restrooms (Continued)

Does at least one lavatory have a clear floor space for a forward approach ... (continued)

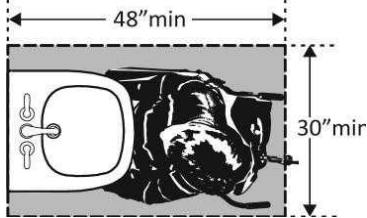

Acceptable Do no less than 17 inches and no greater than 25 inches of the clear floor space extend under the lavatory so that a person using a wheelchair can get close enough to reach the faucet?
 [306.2]

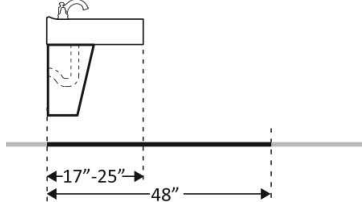

Acceptable Is the front of the lavatory or counter surface, whichever is higher, no more than 34 inches above the floor?
 [606.3]

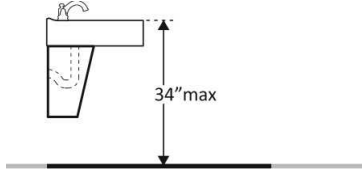

Acceptable Is there at least 27 inches clearance from the floor to the bottom of the lavatory that extends at least 8 inches under the lavatory for knee clearance?
 [306.3.3]

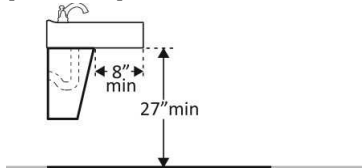

Acceptable Is there toe clearance at least 9 inches high?
 [306.3.3]

Note: Space extending greater than 6 inches beyond the available toe clearance at 9 inches above the floor is not considered toe clearance.

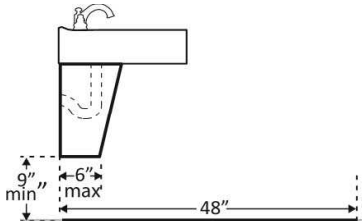

Restrooms (Continued)

Acceptable Are pipes below the lavatory insulated or otherwise configured to protect against contact?
 [606.5]

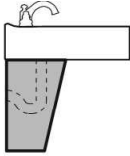

Acceptable Can the faucet be operated without tight grasping, pinching, or twisting of the wrist?

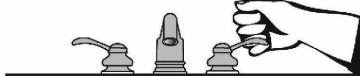

Acceptable Is the force required to activate the faucet no greater than 5 pounds?
 [606.4]

Soap Dispensers and Hand Dryers (2010 Standards 603)

Are the operable parts of the soap dispenser within one of the following reach ranges:

Are the operable parts of the hand dryer or towel dispenser within one of the following reach ranges:

Acceptable Can the operable parts of the hand dryer or towel dispenser be operated without tight grasping, pinching or twisting of the wrist?

Acceptable Is the force required to activate the hand dryer or towel dispenser no greater than 5 pounds?
 [309.4]

Water Closets in Single-User Toilet Rooms and Compartments (Stalls) The 2010 Standards refer to toilets as water closets.

Acceptable Is the centerline of the water closet no less than 16 inches and no greater than 18 inches from the side wall or partition?
 [604.2]

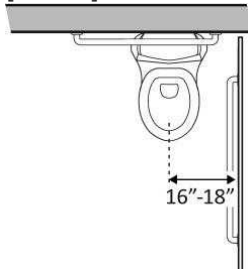

Acceptable Is clearance provided around the water closet measuring at least 60 inches from the side wall and at least 56 inches from the rear wall?*

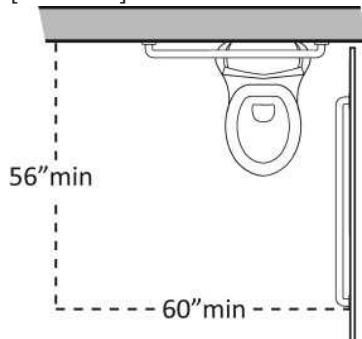

Restrooms (Continued)

If constructed before 3/15/12, clearances around water closets in single user toilet rooms can be 48 inches wide by 66 inches long or 48 inches wide by 56 inches long (depending on the approach to the water closet, see 1991 Standards Figure 28) and the lavatory may overlap that clearance if the door to the room does not swing into the required clearances at fixtures (such as lavatories, water closet and urinals) and the edge of the lavatory is at least 18 inches from the centerline of the water closet

Acceptable Is the height of the water closet no less than 17 inches and no greater than 19 inches above the floor measured to the top of the seat?

[604.4]

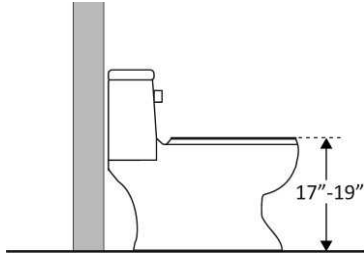

Grab bars

Acceptable Is there a grab bar at least 42 inches long on the side wall?

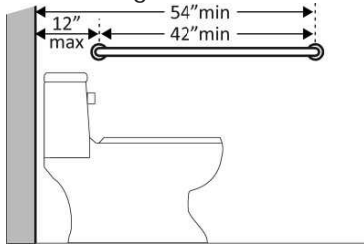

Acceptable Is it located no more than 12 inches from the rear wall?

Acceptable Does it extend at least 54 inches from the rear wall?

[604.5.1]

Acceptable Is it mounted no less than 33 inches and no greater than 36 inches above the floor to the top of the gripping surface?

[609.4]

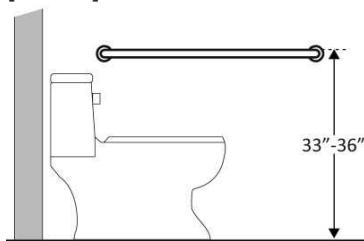

Acceptable Is there at least 12 inches clearance between the grab bar and projecting objects above?*

Acceptable Is the space between the grab bar and the wall 1 1/2 inch?

If constructed before 3/15/2012 grab bars do not need to be relocated; there are no space requirements above and below grab bars in the 1991 Standards

Restrooms (Continued)

Acceptable If the flush control is hand operated, is the operable part located no higher than 48 inches above the floor?
 [604.6]

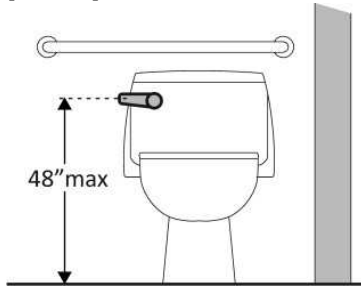

Acceptable If the flush control is hand operated, can it be operated with one hand and without tight grasping, pinching, or twisting of the wrist?

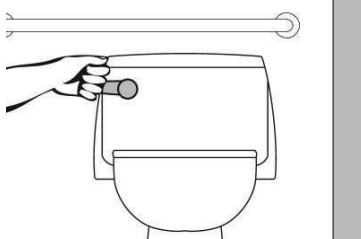

Acceptable Is the force required to activate the flush control no greater than 5 pounds?
 [605.4]

Acceptable Is the flush control on the open side of the water closet?
 [604.6]



Acceptable Is the toilet paper dispenser located no less than 7 inches and no greater than 9 inches from the front of the water closet to the centerline of the dispenser?*

[604.7]

Is the outlet of the dispenser:

Acceptable Located no less than 15 inches and no greater than 48 inches above the floor?

Acceptable Not located behind grab bars?

[604.7]

Acceptable Does the dispenser allow continuous paper flow?

[604.7]

Restrooms (Continued)

Does the dispenser allow continuous paper flow? [604.7] (continued)

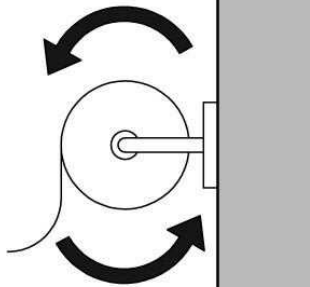

If constructed before 3/15/2012 dispenser does not need to be relocated if it is within reach from the water closet seat; the 1991 Standards do not specify distance from the front of the water closet

Toilet Compartments (Stalls)

Note: See 2010 Standards 604.8.1.2 Doors for maneuvering clearance requirements on the push side of the door and side approaches to the pull side of the door

If constructed before 3/15/2012 door pulls do not need to be added; door pulls are not required in the 1991 Standards

Urinals Height and Depth. 605.2

Restrooms (Continued)

Signs

Signs

If there are signs designating permanent rooms and spaces not likely to change over time, e.g. room numbers and letters, room names, and exit signs:

[216.2]

- Acceptable Do text characters contrast with their backgrounds?
[703.5]
- Acceptable Are text characters raised?
[703.2]
- Acceptable Is there Braille?
[703.3]
- Acceptable Is the sign mounted:
On the wall on the latch side of the door?
[703.4.2]

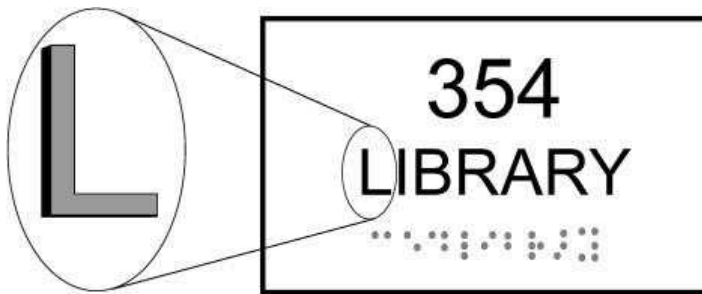

Note: Signs are permitted on the push side of doors with closers and without hold-open devices.

- Acceptable With clear floor space beyond the arc of the door swing between the closed position and 45-degree open position, at least 18 x 18 inches centered on the tactile characters?
[703.4.2]

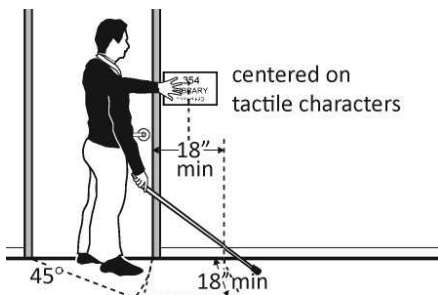

- Acceptable So the baseline of the lowest character is at least 48 inches above the floor and the baseline of the highest character is no more than 60 inches above the floor? *
[703.4.1]

Signs (Continued)

So the baseline of the lowest character is at least 48 inches above the flo... (continued)

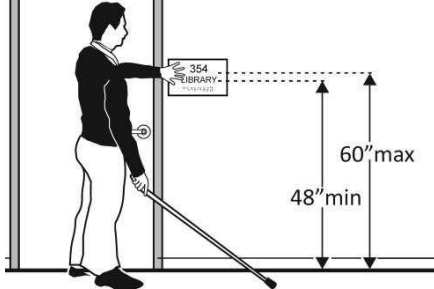

Note: If the sign is at double doors with one active leaf, the sign should be on the inactive leaf; if both leaves are active, the sign should be on the wall to the right of the right leaf.

If there are signs that provide direction to or information about interior spaces:

Acceptable Do text characters contrast with their backgrounds?
[703.5]

Acceptable Is the sign mounted so that characters are at least 40 inches above the floor?
[703.5.6]

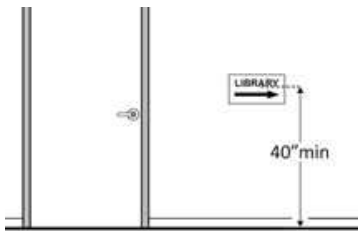

Note: Raised characters and Braille are not required.

Signs (Continued)

Apartments

304 Apartments

Doors

Usable doors have a clear opening of at least a nominal 32 inches (no less than 31 and 5/8 inches) between the face of the door and the stop, when the door is open to 90 degrees.

Note: Because of normal installation practices, usable doorways can vary from the 32-inch clear width by a nominal amount. Tolerances of inch to 3/8 inch are considered an acceptable range for usable doors.

Acceptable Is there sufficient maneuvering room?

Approach Direction	Type of Use	Maneuvering Clearance	
	Door Side	Perpendicular to Doorway	Parallel to Doorway (beyond latch)
From front	Pull	60 inches	18 inches
From front	Pull	48 inches	0 inches
From front	Pull	60 inches	36 inches
From front	Pull	54 inches	42 inches
From front	Pull	42 inches	22 inches
From front	Pull	48 inches	24 inches
From front	Pull	42 inches	24 inches

Acceptable Door thresholds are no more than inch high or inch high if beveled with a slope no greater than 1:2.
 Acceptable Doors leading to closets with a depth greater than 24 inches have a nominal 32-inch clear width.

Note: This is an FHA best practice.

Acceptable All secondary doors that provide passage onto exterior areas of the unit (decks, patios, balconies, etc.) have a nominal 32-inch clear width.

Acceptable Do all entry doors to accessible rooms and other interior doors (except doors on shallow closets) allow at least 32" of clear passage width to accommodate persons who use wheelchairs, crutches, and walkers?
 [ADA Stds. 9.2.2(3); 4.13.5]

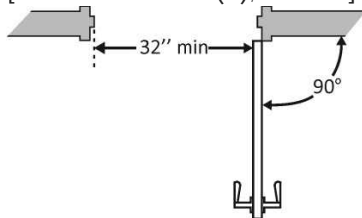

Apartments (Continued)

Acceptable Do room doors require 5 lbs. or less of force to open or have power openers?

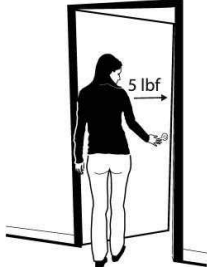

Acceptable Is the door hardware (levers, pulls, panic bars, etc.) on all entry doors to accessible rooms and other passage doors within the room usable with one hand, without tight grasping, pinching, or twisting of the wrist, since many persons with disabilities may not have high manual dexterity or use of both hands? [ADA Stds. 9.2.2(3); 4.13.9]

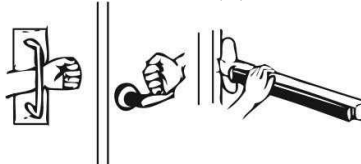

Acceptable Is the security latch or bolt on the hall door mounted no higher than 48" above the floor so it is within the reach of persons who use wheelchairs and is it operable with one hand, without tight grasping, pinching or twisting of the wrist? [ADA Stds. 9.2.2(3); 4.13.9]

Room to Maneuver

Acceptable There is an accessible route starting at the main entry door that leads, uninterrupted, through each room and connects to all spaces and elements within the unit (e.g., bedrooms, bathrooms, living room, etc.).

Note: The FHA does not require an accessible route to unfinished basements or garages.

Acceptable The route maintains at least 36 inches in width throughout the unit

Acceptable Throughout the interior of the unit, changes in level are no more than 1/4 inch high or 1/2 inch high if beveled with a slope no greater than 1:2.

In instances where the unit is a multistory unit in a covered building with an elevator:

Acceptable The primary entry to the unit is located on the same floor that is served by the elevator; and The story served by the elevator meets FHA Requirements 3-7

Changes in level vary depending on whether the door is a primary or secondary door and the makeup of the material of the outside landing surface. Measurements for changes in level should be taken from the finished floor or fully compressed carpet.

In instances where the primary entry door to a dwelling unit has direct exterior access (e.g., a garden style building):

Acceptable The landing material outside of the door is pervious, the exterior floor is level with the interior floor of the dwelling unit.

Acceptable The landing material outside of the door is impervious, the exterior floor is no more than 1/4 inch below the interior floor of the dwelling unit.

Acceptable Thresholds at these doors are a maximum 1/4 inch plus the change in level noted above. They must be beveled at a slope no greater than 1:2.

Note: This could allow an exterior maximum rise of 1-1/4 inch, which must be beveled with a slope no greater than 1:2.

In instances where secondary doors lead to decks, patios, balconies, etc.:

Acceptable The landing material outside of the door is pervious, the change in level is no more than 1/4 inch on the

Apartments (Continued)

The landing material outside of the door is pervious, the change in level i... (continued)
 exterior side.

Acceptable The landing material outside of the door is impervious, the change in level is no more than 4 inches on the exterior side.

Note: This could allow an exterior maximum rise of 4-3/4 inch.

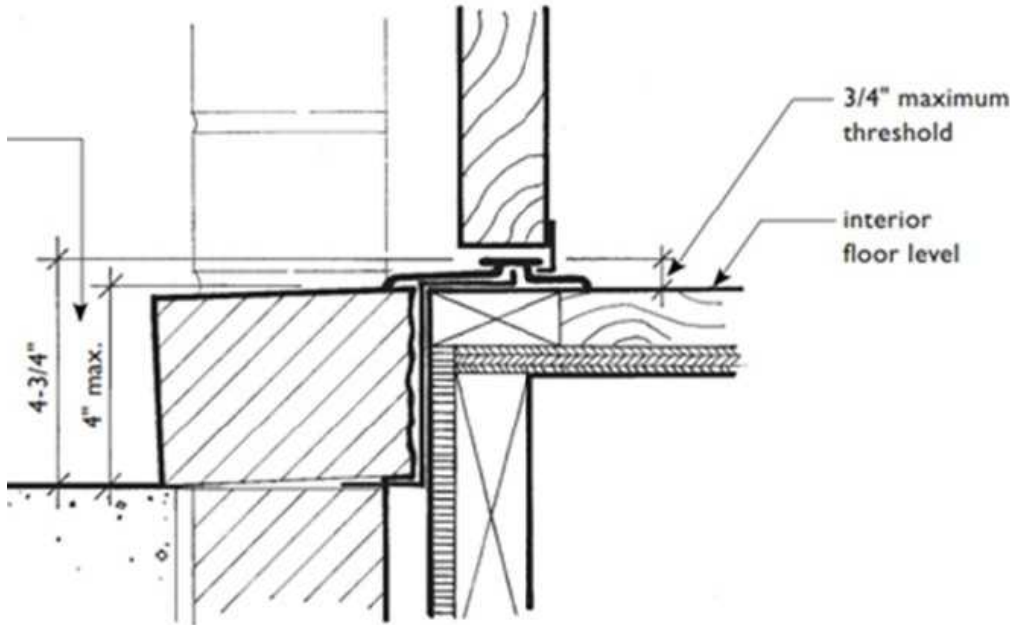

354 Apartments

Doors

Usable doors have a clear opening of at least a nominal 32 inches (no less than 31 and 5/8 inches) between the face of the door and the stop, when the door is open to 90 degrees.

Note: Because of normal installation practices, usable doorways can vary from the 32-inch clear width by a nominal amount. Tolerances of inch to 3/8 inch are considered an acceptable range for usable doors.

Acceptable Is there sufficient maneuvering room?

Type of Use		Maneuvering Clearance	
Approach Direction	Door Side	Perpendicular to Doorway	Parallel to Doorway (beyond latch)
From front	Pull	60 inches	18 inches
From front	Pull	48 inches	0 inches
From front	Pull	60 inches	36 inches
From front	Pull	54 inches	42 inches
From front	Pull	42 inches	22 inches
From front	Pull	48 inches	24 inches
From front	Pull	42 inches	24 inches

Apartments (Continued)

Acceptable Door thresholds are no more than 1/2 inch high or 3/4 inch high if beveled with a slope no greater than 1:2.
 Acceptable Doors leading to closets with a depth greater than 24 inches have a nominal 32-inch clear width.

Note: This is an FHA best practice.

Acceptable All secondary doors that provide passage onto exterior areas of the unit (decks, patios, balconies, etc.) have a nominal 32-inch clear width.

Acceptable Do all entry doors to accessible rooms and other interior doors (except doors on shallow closets) allow at least 32" of clear passage width to accommodate persons who use wheelchairs, crutches, and walkers?
 [ADA Stds. 9.2.2(3); 4.13.5]

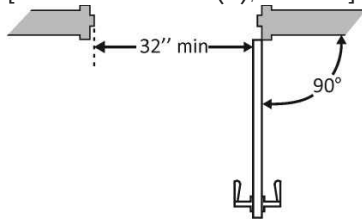

Acceptable Do room doors require 5 lbs. or less of force to open or have power openers?

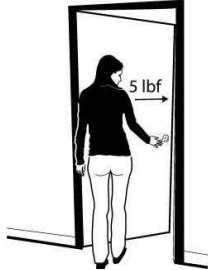

Acceptable Is the door hardware (levers, pulls, panic bars, etc.) on all entry doors to accessible rooms and other passage doors within the room usable with one hand, without tight grasping, pinching, or twisting of the wrist, since many persons with disabilities may not have high manual dexterity or use of both hands?
 [ADA Stds. 9.2.2(3); 4.13.9]

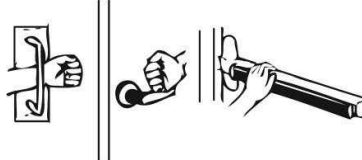

Acceptable Is the security latch or bolt on the hall door mounted no higher than 48" above the floor so it is within the reach of persons who use wheelchairs and is it operable with one hand, without tight grasping, pinching or twisting of the wrist? [ADA Stds. 9.2.2(3); 4.13.9]

Room to Maneuver

Acceptable There is an accessible route starting at the main entry door that leads, uninterrupted, through each room and connects to all spaces and elements within the unit (e.g., bedrooms, bathrooms, living room, etc.).

Note: The FHA does not require an accessible route to unfinished basements or garages.

Acceptable The route maintains at least 36 inches in width throughout the unit

Acceptable Throughout the interior of the unit, changes in level are no more than 1/2 inch high or 3/4 inch high if beveled with a slope no greater than 1:2.

Acceptable Changes in level greater than 1/2 inch high are ramped with a slope no greater than 1:12 (8.33%).

In instances where the unit is a multistory unit in a covered building with an elevator:

Apartments (Continued)

Acceptable The primary entry to the unit is located on the same floor that is served by the elevator; and The story served by the elevator meets FHA Requirements 3-7

Changes in level vary depending on whether the door is a primary or secondary door and the makeup of the material of the outside landing surface. Measurements for changes in level should be taken from the finished floor or fully compressed carpet.

In instances where the primary entry door to a dwelling unit has direct exterior access (e.g., a garden style building):

Acceptable The landing material outside of the door is pervious, the exterior floor is level with the interior floor of the dwelling unit.

Acceptable The landing material outside of the door is impervious, the exterior floor is no more than 1/4 inch below the interior floor of the dwelling unit.

Acceptable Thresholds at these doors are a maximum 1/4 inch plus the change in level noted above. They must be beveled at a slope no greater than 1:2.

Note: This could allow an exterior maximum rise of 1-1/4 inch, which must be beveled with a slope no greater than 1:2.

In instances where secondary doors lead to decks, patios, balconies, etc.:

Acceptable The landing material outside of the door is pervious, the change in level is no more than 1/4 inch on the exterior side.

Acceptable The landing material outside of the door is impervious, the change in level is no more than 4 inches on the exterior side.

Note: This could allow an exterior maximum rise of 4-3/4 inch.

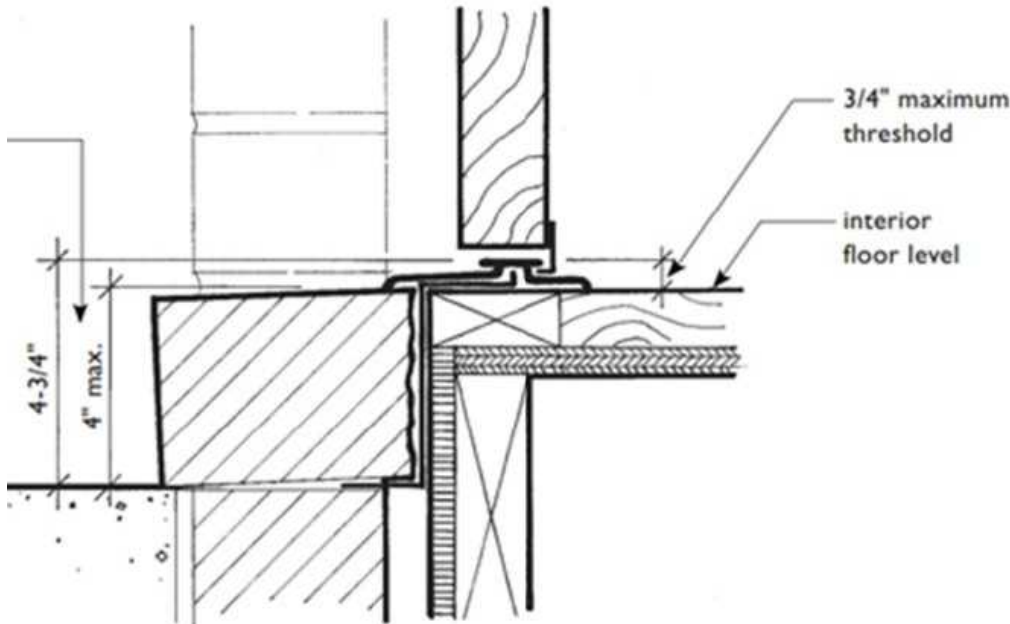

Apartments (Continued)

254 Apartments

Doors

Usable doors have a clear opening of at least a nominal 32 inches (no less than 31 and 5/8 inches) between the face of the door and the stop, when the door is open to 90 degrees.

Note: Because of normal installation practices, usable doorways can vary from the 32-inch clear width by a nominal amount. Tolerances of 1/8 inch to 3/8 inch are considered an acceptable range for usable doors.

Acceptable Is there sufficient maneuvering room?

Type of Use		Maneuvering Clearance	
Approach Direction	Door Side	Perpendicular to Doorway	Parallel to Doorway (beyond latch)
From front	Pull	60 inches	18 inches
From front	Pull	48 inches	0 inches
From front	Pull	60 inches	36 inches
From front	Pull	54 inches	42 inches
From front	Pull	42 inches	22 inches
From front	Pull	48 inches	24 inches
From front	Pull	42 inches	24 inches

Acceptable Door thresholds are no more than 1/2 inch high or 3/4 inch high if beveled with a slope no greater than 1:2.
 Acceptable Doors leading to closets with a depth greater than 24 inches have a nominal 32-inch clear width.

Note: This is an FHA best practice.

Acceptable All secondary doors that provide passage onto exterior areas of the unit (decks, patios, balconies, etc.) have a nominal 32-inch clear width.

Acceptable Do all entry doors to accessible rooms and other interior doors (except doors on shallow closets) allow at least 32" of clear passage width to accommodate persons who use wheelchairs, crutches, and walkers? [ADA Stds. 9.2.2(3); 4.13.5]

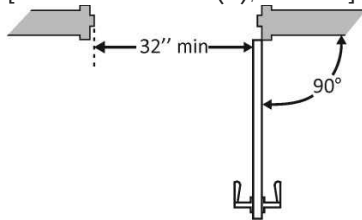

Acceptable Do room doors require 5 lbs. or less of force to open or have power openers?

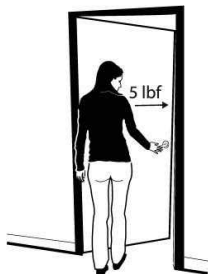

Apartments (Continued)

Acceptable Is the door hardware (levers, pulls, panic bars, etc.) on all entry doors to accessible rooms and other passage doors within the room usable with one hand, without tight grasping, pinching, or twisting of the wrist, since many persons with disabilities may not have high manual dexterity or use of both hands? [ADA Stds. 9.2.2(3); 4.13.9]

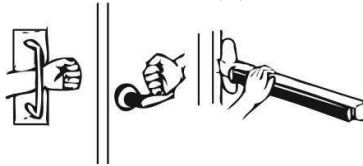

Acceptable Is the security latch or bolt on the hall door mounted no higher than 48" above the floor so it is within the reach of persons who use wheelchairs and is it operable with one hand, without tight grasping, pinching or twisting of the wrist? [ADA Stds. 9.2.2(3); 4.13.9]

Room to Maneuver

Acceptable There is an accessible route starting at the main entry door that leads, uninterrupted, through each room and connects to all spaces and elements within the unit (e.g., bedrooms, bathrooms, living room, etc.).

Note: The FHA does not require an accessible route to unfinished basements or garages.

Acceptable The route maintains at least 36 inches in width throughout the unit

Acceptable Throughout the interior of the unit, changes in level are no more than 1/4 inch high or 1/2 inch high if beveled with a slope no greater than 1:2.

Acceptable Changes in level greater than 1/4 inch high are ramped with a slope no greater than 1:12 (8.33%).

In instances where the unit is a multistory unit in a covered building with an elevator:

Acceptable The primary entry to the unit is located on the same floor that is served by the elevator; and The story served by the elevator meets FHA Requirements 3-7

Changes in level vary depending on whether the door is a primary or secondary door and the makeup of the material of the outside landing surface. Measurements for changes in level should be taken from the finished floor or fully compressed carpet.

In instances where the primary entry door to a dwelling unit has direct exterior access (e.g., a garden style building):

Acceptable The landing material outside of the door is pervious, the exterior floor is level with the interior floor of the dwelling unit.

Acceptable The landing material outside of the door is impervious, the exterior floor is no more than 1/4 inch below the interior floor of the dwelling unit.

Acceptable Thresholds at these doors are a maximum 1/4 inch plus the change in level noted above. They must be beveled at a slope no greater than 1:2.

Note: This could allow an exterior maximum rise of 1-1/4 inch, which must be beveled with a slope no greater than 1:2.

In instances where secondary doors lead to decks, patios, balconies, etc.:

Acceptable The landing material outside of the door is pervious, the change in level is no more than 1/4 inch on the exterior side.

Acceptable The landing material outside of the door is impervious, the change in level is no more than 4 inches on the exterior side.

Apartments (Continued)

Note: This could allow an exterior maximum rise of 4-3/4 inch.

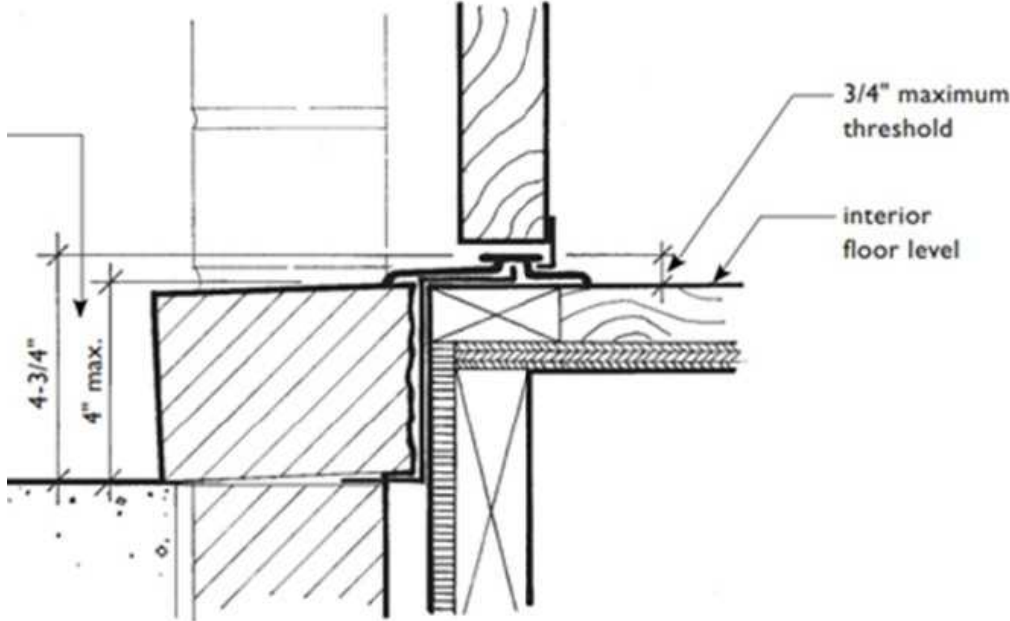

Apartment Controls

304 Apartment Controls

Controls

- Acceptable Are the drapery wands and controls on fixed lamps and HVAC units easily operable with one hand, without tight grasping, pinching or twisting of the wrist, since many persons with disabilities may not have high manual dexterity or use of both hands? [ADA Stds. 9.2.2(5); 4.27.4]
- Acceptable Are all drapery control wands, fixed lamps and HVAC controls in accessible guestrooms placed within 54" of the floor for side approach or 48" of the floor for forward approach so persons who use wheelchairs can approach and use the controls? [ADA Stds. 9.2.2(5); 4.27.3]
- Acceptable Are the rod and shelf in the clothes closet or wall mounted unit within 54" of the floor for side approach or 48" of the floor for forward approach so persons who use wheelchairs can approach and use the rod and shelf? [ADA Stds. 9.2.2(4); 4.25.3]
- Acceptable Is there a clear floor space at least 30 inches wide by at least 48 inches long for a forward or parallel approach? [305.3]

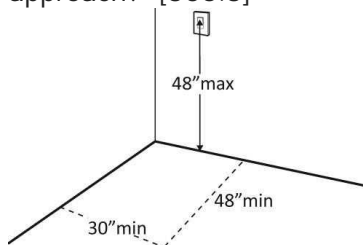

Apartment Controls (Continued)

Acceptable Are the operable parts no higher than 48 inches above the floor?* [309.3, 308]

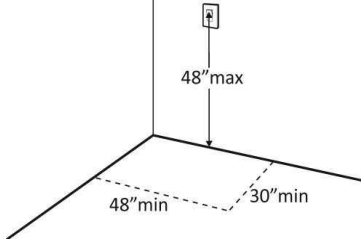

Acceptable Can the control be operated with one hand and without tight grasping, pinching, or twisting of the wrist? [309.4]

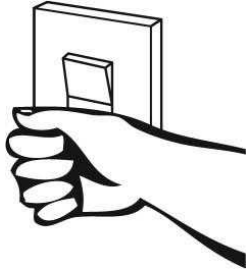

Apartment Controls (Continued)

354 Apartment Controls

Controls

- Acceptable Are the drapery wands and controls on fixed lamps and HVAC units easily operable with one hand, without tight grasping, pinching or twisting of the wrist, since many persons with disabilities may not have high manual dexterity or use of both hands? [ADA Stds. 9.2.2(5); 4.27.4]
- Acceptable Are all drapery control wands, fixed lamps and HVAC controls in accessible guestrooms placed within 54" of the floor for side approach or 48" of the floor for forward approach so persons who use wheelchairs can approach and use the controls? [ADA Stds. 9.2.2(5); 4.27.3]
- Acceptable Are the rod and shelf in the clothes closet or wall mounted unit within 54" of the floor for side approach or 48" of the floor for forward approach so persons who use wheelchairs can approach and use the rod and shelf? [ADA Stds. 9.2.2(4); 4.25.3]
- Acceptable Are the operable parts no higher than 48 inches above the floor?* [309.3, 308]

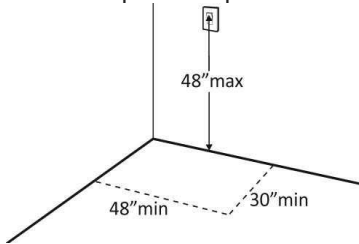

- Acceptable Can the control be operated with one hand and without tight grasping, pinching, or twisting of the wrist? [309.4]

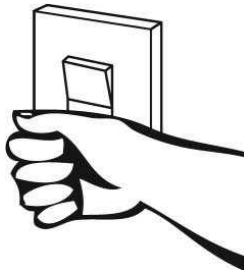

Apartment Controls (Continued)

254 Apartment Controls

Controls

- Acceptable Are the drapery wands and controls on fixed lamps and HVAC units easily operable with one hand, without tight grasping, pinching or twisting of the wrist, since many persons with disabilities may not have high manual dexterity or use of both hands? [ADA Stds. 9.2.2(5); 4.27.4]
- Acceptable Are all drapery control wands, fixed lamps and HVAC controls in accessible guestrooms placed within 54" of the floor for side approach or 48" of the floor for forward approach so persons who use wheelchairs can approach and use the controls? [ADA Stds. 9.2.2(5); 4.27.3]
- Acceptable Are the rod and shelf in the clothes closet or wall mounted unit within 54" of the floor for side approach or 48" of the floor for forward approach so persons who use wheelchairs can approach and use the rod and shelf? [ADA Stds. 9.2.2(4); 4.25.3]
- Acceptable Is there a clear floor space at least 30 inches wide by at least 48 inches long for a forward or parallel approach? [305.3]

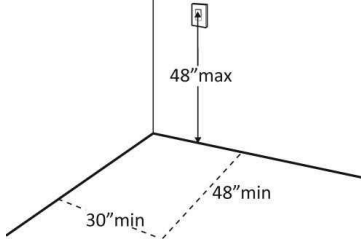

- Acceptable Are the operable parts no higher than 48 inches above the floor?*[309.3, 308]

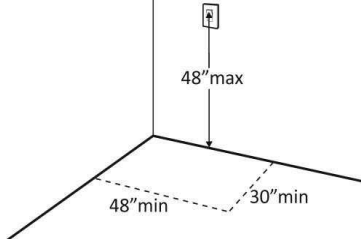

- Acceptable Can the control be operated with one hand and without tight grasping, pinching, or twisting of the wrist? [309.4]

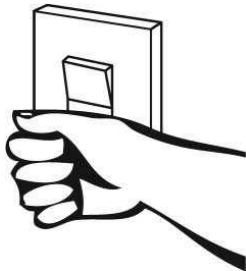

Apartment Controls (Continued)

Kitchens

One Bedroom Apartment Kitchens

Usable kitchens are included under requirement 7 of the Fair Housing Act. A clear floor space positioned at fixtures and proper clearance, among other criteria, in order to provide accessibility to people with disabilities is required.

Acceptable Is there is 30 x 48 inches of clear floor space centered on the sink to allow for a parallel approach?

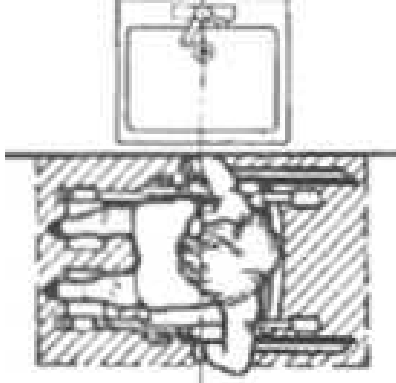

Note: This measurement is taken from the center of the sink basin.

Acceptable In instances where there are multiple sink bowls, is there is 30 x 48 inches of clear floor space centered on the overall sink?



Acceptable Is there is 30 x 48 inches of clear floor space centered on the cooktop/range to allow for a parallel approach?

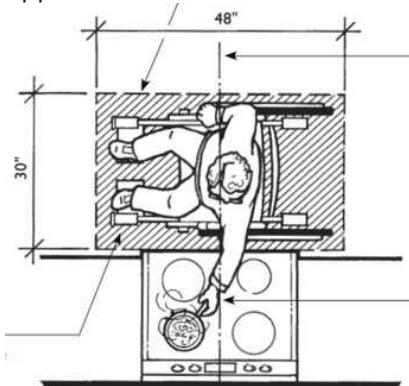

Note: Cooktops with removable base cabinets that allow for knee clearance of at least 30 inches wide by at least 27 inches high can have a centered forward approach.

Kitchens (Continued)

Acceptable Do additional appliances such as refrigerators, dishwashers, freezers, wall-mounted microwaves/ovens, and trash compactors have 30 x 48 inches of clear floor space for either a: Centered parallel approach; or Centered forward approach?

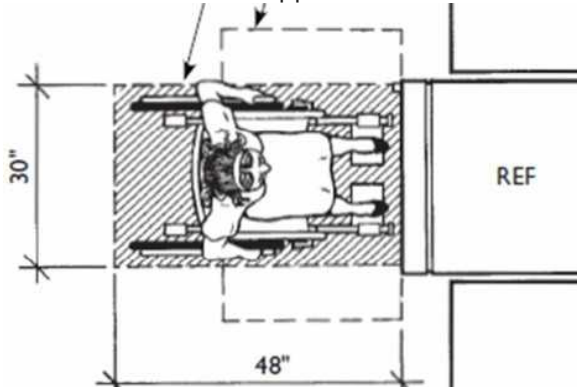

Acceptable Is there is a minimum clearance of 40 inches between all opposing elements within the kitchen work area such as base cabinets, counter top edges, appliances, or walls?

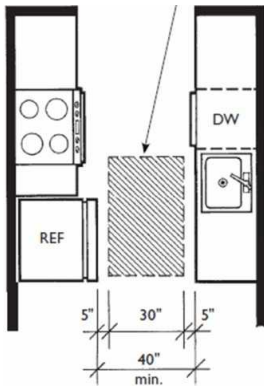

Note: This measurement is taken from the face of the appliance (excluding handles or controls) to whichever opposing element projects the furthest (cabinet face, countertop edge, wall, etc.).

Acceptable In instances where kitchens have an island, the 40-inch minimum clearance is maintained around all edges within the kitchen work area?

Acceptable In U-shaped kitchens, is there is a 60-inch diameter turning circle at the base of the kitchen?

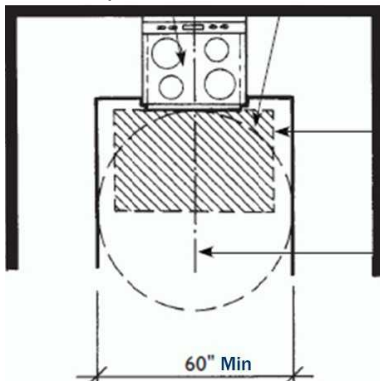

Note: The 60-inch diameter turning circle must not be encroached upon by countertops, cabinets, refrigerators (excluding handles), etc.

Do narrow U-shaped kitchens (lacking a 60-inch diameter turning circle) meet the following requirements:

Acceptable There is at least 40 inches between all opposing elements.

Kitchens (Continued)

- Acceptable The sink or cooktop is located at the base of the kitchen.
- Acceptable There is 30 x 48 inches of clear floor space centered on the sink or cooktop for a forward approach (this can include knee space).
- Defective All pipes are covered by a removable pipe protection and panel, or wrapped with padded insulation materials.

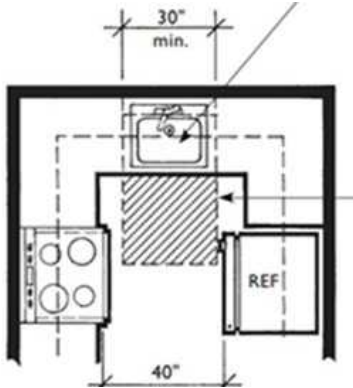

Note: Because ranges do not allow for knee space, a narrow U-shaped kitchen with a range at the base will not meet the FHA regulations.

In instances where electrical outlets and switches are mounted over base cabinets without knee space, the accessible outlets and switches meet the following requirements:

- Acceptable Electrical outlets and switches are mounted at least 36 inches from any corner to allow for a parallel approach.

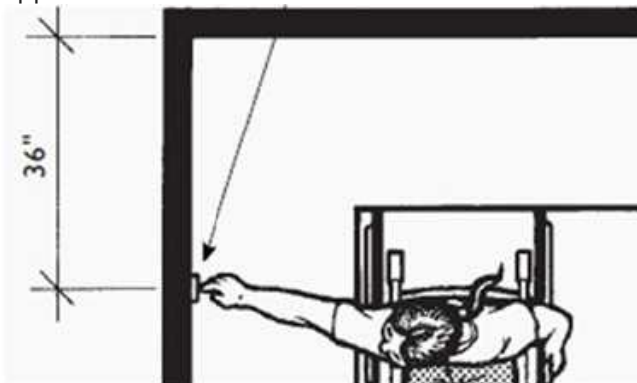

- Acceptable Electrical outlets and switches are mounted no higher than 46 inches.

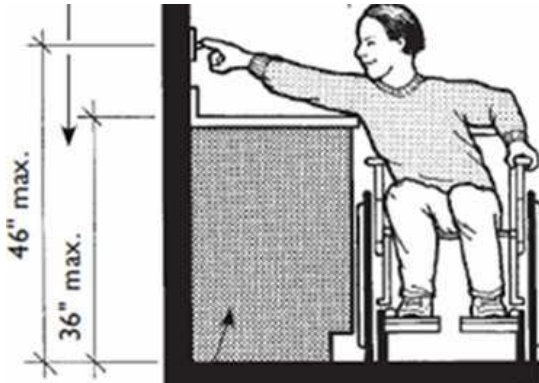

- Acceptable Countertop depths do not exceed 25 inches.
- Note: HUD allows a maximum countertop projection of 25 1/2 inches.



Colorado Inspection Services, LLC

Prepared for:
1 Main St

Kitchens (Continued)

Acceptable Countertops do not exceed 36 inches in height.

Kitchens (Continued)

Two Bedroom Apartment Kitchens

Usable kitchens are included under requirement 7 of the Fair Housing Act. A clear floor space positioned at fixtures and proper clearance, among other criteria, in order to provide accessibility to people with disabilities is required.

Acceptable Is there is 30 x 48 inches of clear floor space centered on the sink to allow for a parallel approach?

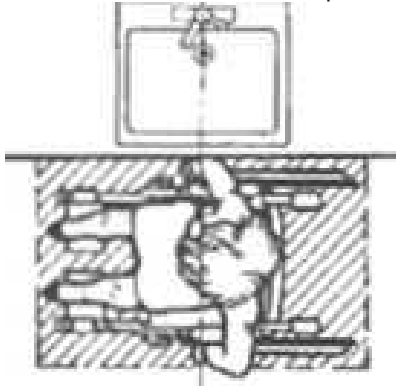

Note: This measurement is taken from the center of the sink basin.

Acceptable In instances where there are multiple sink bowls, is there is 30 x 48 inches of clear floor space centered on the overall sink?



Acceptable Is there is 30 x 48 inches of clear floor space centered on the cooktop/range to allow for a parallel approach?

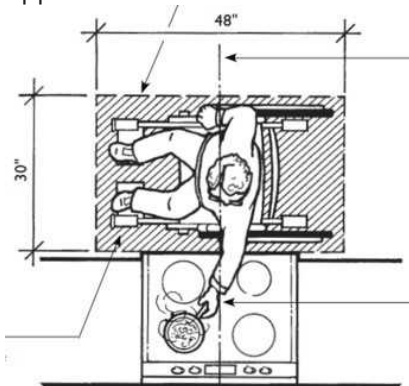

Note: Cooktops with removable base cabinets that allow for knee clearance of at least 30 inches wide by at least 27 inches high can have a centered forward approach.

Kitchens (Continued)

Acceptable Do additional appliances such as refrigerators, dishwashers, freezers, wall-mounted microwaves/ovens, and trash compactors have 30 x 48 inches of clear floor space for either a: Centered parallel approach; or Centered forward approach?

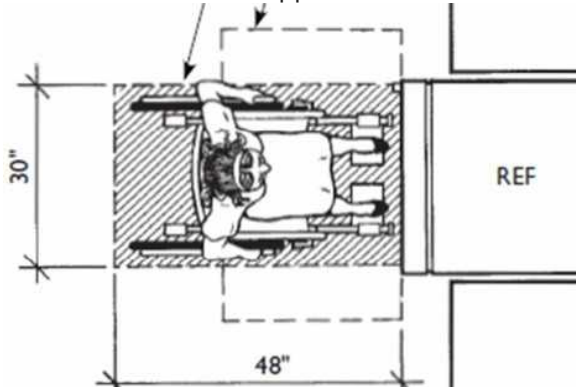

Acceptable Is there is a minimum clearance of 40 inches between all opposing elements within the kitchen work area such as base cabinets, counter top edges, appliances, or walls?

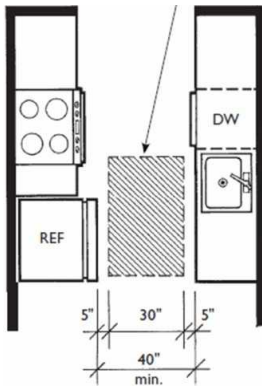

Note: This measurement is taken from the face of the appliance (excluding handles or controls) to whichever opposing element projects the furthest (cabinet face, countertop edge, wall, etc.).

Defective In instances where kitchens have an island, the 40-inch minimum clearance is maintained around all edges within the kitchen work area? Refrigerator decreases path to less than 40"



Note: The 60-inch diameter turning circle must not be encroached upon by countertops, cabinets, refrigerators (excluding handles), etc.

Do narrow U-shaped kitchens (lacking a 60-inch diameter turning circle) meet the following requirements:

Acceptable There is knee clearance at least 30 inches wide by at least 27 inches high.

Acceptable There is 30 x 48 inches of clear floor space centered on the sink or cooktop for a forward approach (this can include knee space).

Kitchens (Continued)

Defective All pipes are covered by a removable pipe protection and panel, or wrapped with padded insulation materials.

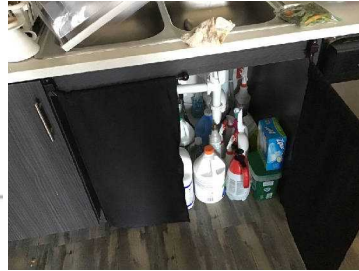
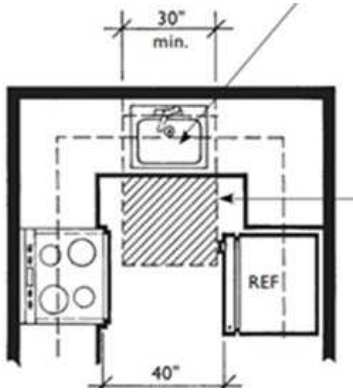

Note: Because ranges do not allow for knee space, a narrow U-shaped kitchen with a range at the base will not meet the FHA regulations.

In instances where electrical outlets and switches are mounted over base cabinets without knee space, the accessible outlets and switches meet the following requirements:

Acceptable Electrical outlets and switches are mounted at least 36 inches from any corner to allow for a parallel approach.



Acceptable Electrical outlets and switches are mounted no higher than 46 inches.

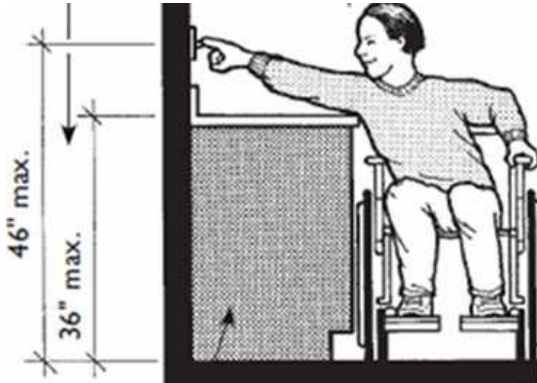

Acceptable Countertop depths do not exceed 25 inches.

Note: HUD allows a maximum countertop projection of 25 1/2 inches.

Acceptable Countertops do not exceed 36 inches in height.

Kitchens (Continued)

Bathrooms

304 Apartment Bathrooms

Usable bathrooms are included under Requirement 7 of the Fair Housing Act. A clear floor space positioned at fixtures and proper clearance, among other criteria, in order to provide accessibility to people with disabilities. is required.

Acceptable Is the bathroom is along an accessible route with a nominal 32-inch clear door opening?

Acceptable Are switches, outlets, and controls are located in accessible locations?

Acceptable Are walls are reinforced for the installation of grab bars?

Acceptable Is there is sufficient maneuvering space within the bathroom to permit a person to enter and exit the room, close and reopen the door, and use fixtures?

In instances where there is a powder room in the unit, is the powder room:

Acceptable Along an accessible route with a door that provides a nominal 32-inch clear opening; and

Acceptable Equipped with switches, outlets, and controls in accessible locations.

Acceptable In a multistory unit in an elevator building, is there either a usable powder room (Section 7.12) or a usable bathroom (Section 7.11) on the same level that is served by the elevator?

If only a powder room is provided on the level that is served by the elevator:

Acceptable Is there sufficient maneuvering space within the bathroom to permit a person to enter and exit the room, close and reopen the door, and use fixtures?

The Fair Housing Act provides two sets of specifications to design bathrooms that are usable by people with disabilities. Though there are other differences, Specification B Bathrooms offer greater access to the tub than Specification A Bathrooms.

If the Specification A design is selected, all bathrooms in the unit must comply with Specification A standards (Section 7.14). This includes access to all fixtures in each Specification A

Bathroom (e.g., two lavatories in one bathroom would both need to meet FHA regulations).

If the Specification B design is selected, only one bathroom in the unit, and only one of each type of fixture within the bathroom, must comply with Specification B standards (Section

7.15). All other bathrooms in the unit must meet the usable bathroom requirements (Section 7.11), exempting maneuvering clearances and clear floor space requirements at fixtures.

Specification A and B Bathrooms

Bathrooms (Continued)

Specification A Bathrooms

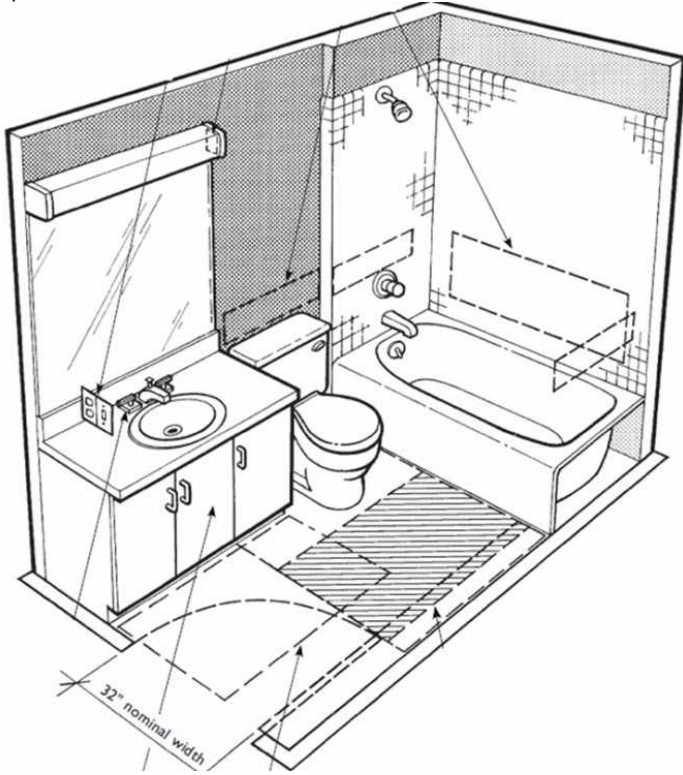

Acceptable Does the door have a minimum clear width of 32 inches nominal and meets all other usable door requirements (Sections 3.12-3.13)?

Note: A parallel approach to the tub is also possible if proper knee space or removable base cabinets are provided.

Acceptable Is the clear floor space at the lavatory:
30 x 48 inches of clear floor space parallel to and centered on the sink basin; or a removable vanity cabinet to provide knee space for a forward approach?

Bathrooms (Continued)

Specification B Bathrooms

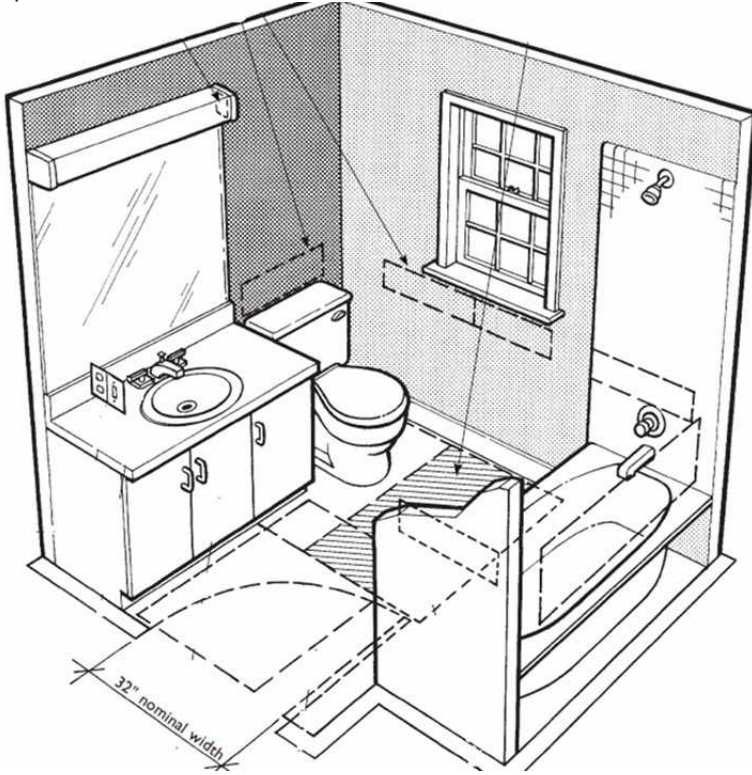

Acceptable Does the door have a minimum clear width of 32 inches nominal and meets all other usable door requirements (Sections 3.123.13)?

Acceptable Is the clear floor space at the lavatory:
30 x 48 inches of clear floor space parallel to and centered on the sink basin; or a removable vanity cabinet to provide knee space for a forward approach?

If knee space is provided at the lavatory:

Acceptable Is no more than 19 inches of the 30 x 48 inches of required clear floor space extended under the lavatory?

Acceptable Is The top fixture rim is a maximum of 34 inches, with the apron at least 27 inches?

Specification A & B Bathroom Toilets

Is one of the following three clear floor spaces is provided at toilets:

The centerline of the toilet is 18 inches from the adjacent side wall and at least 15 inches from a wall-hung lavatory or vanity.

There is a minimum of 48 x 66 inches of clear floor space, excluding the toilet and the wallhung lavatory or vanity.

Bathrooms (Continued)

The centerline of the toilet is 18 inches from the adjacent side wall and a... (continued)

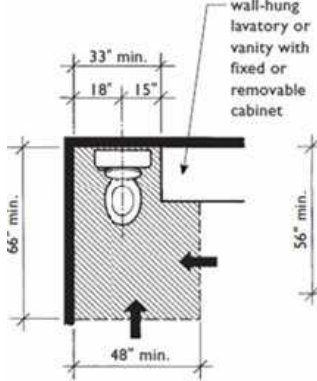

Is one of the following three clear floor spaces provided at tubs:

There is a minimum of 30 x 60 inches of clear floor space adjacent to the tub, excluding a lavatory with knee space.

Note: for use with Specification A bathrooms only.

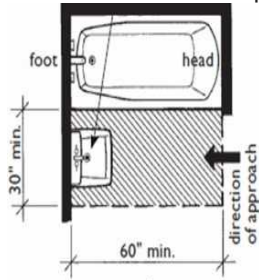

1
 Specification "A"
 Bathrooms
 30" X 60"

There is a minimum of 48 x 60 inches of clear floor space adjacent to the tub, excluding a toilet with a centerline at least 18 inches from the tub.

Note: for use with Specification A bathrooms only.

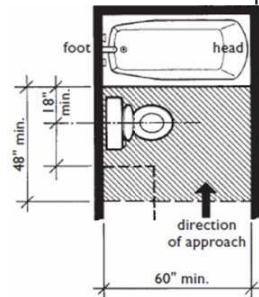

2
 Specification "A"
 Bathrooms
 48" X 60"

Bathrooms (Continued)

There is a minimum of 30 x 48 inches of clear floor space adjacent to the tub.

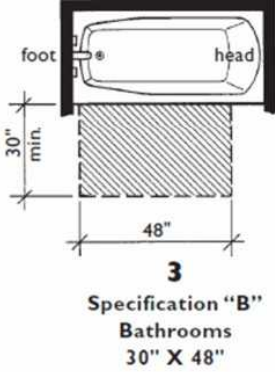

Showers

Bathrooms (Continued)

354 north Apartment Bathrooms

Usable bathrooms are included under Requirement 7 of the Fair Housing Act. A clear floor space positioned at fixtures and proper clearance, among other criteria, in order to provide accessibility to people with disabilities. is required.

Acceptable Is the bathroom is along an accessible route with a nominal 32-inch clear door opening?

Acceptable Are switches, outlets, and controls are located in accessible locations?

Acceptable Are walls are reinforced for the installation of grab bars?

Acceptable Is there is sufficient maneuvering space within the bathroom to permit a person to enter and exit the room, close and reopen the door, and use fixtures?

In instances where there is a powder room in the unit, is the powder room:

Acceptable Along an accessible route with a door that provides a nominal 32-inch clear opening; and

Acceptable Equipped with switches, outlets, and controls in accessible locations.

Acceptable In a multistory unit in an elevator building, is there either a usable powder room (Section 7.12) or a usable bathroom (Section 7.11) on the same level that is served by the elevator?

If only a powder room is provided on the level that is served by the elevator:

Acceptable Is there sufficient maneuvering space within the bathroom to permit a person to enter and exit the room, close and reopen the door, and use fixtures?

The Fair Housing Act provides two sets of specifications to design bathrooms that are usable by people with disabilities. Though there are other differences, Specification B Bathrooms offer greater access to the tub than Specification A Bathrooms.

If the Specification A design is selected, all bathrooms in the unit must comply with Specification A standards (Section 7.14). This includes access to all fixtures in each Specification A

Bathroom (e.g., two lavatories in one bathroom would both need to meet FHA regulations).

If the Specification B design is selected, only one bathroom in the unit, and only one of each type of fixture within the bathroom, must comply with Specification B standards (Section

7.15). All other bathrooms in the unit must meet the usable bathroom requirements (Section 7.11), exempting maneuvering clearances and clear floor space requirements at fixtures.

Specification A and B Bathrooms

Bathrooms (Continued)

Specification A Bathrooms

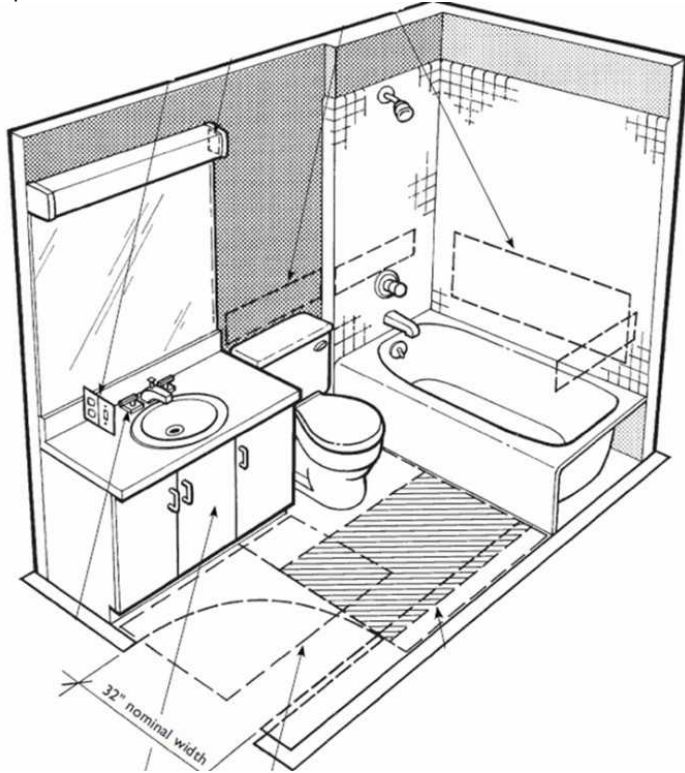

- Acceptable Does the door have a minimum clear width of 32 inches nominal and meets all other usable door requirements (Sections 3.12-3.13)?
- Acceptable Is there is 30 x 48 inches of clear floor space outside the swing of the door that provides a forward approach to the tub?
- Note: A parallel approach to the tub is also possible if proper knee space or removable base cabinets are provided.
- Acceptable Is the clear floor space at the lavatory:
30 x 48 inches of clear floor space parallel to and centered on the sink basin; or a removable vanity cabinet to provide knee space for a forward approach?

Bathrooms (Continued)

Specification B Bathrooms

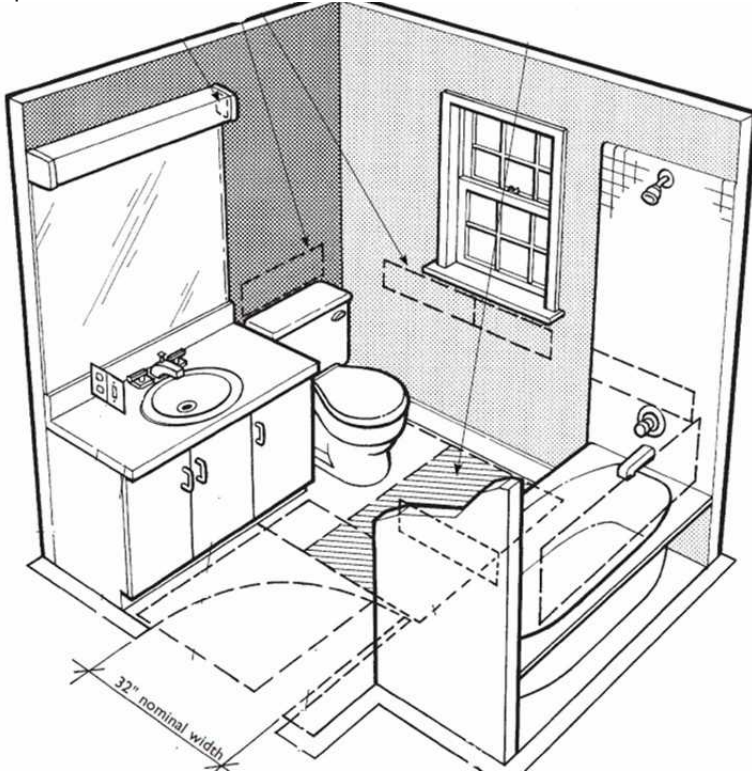

- Acceptable Does the door have a minimum clear width of 32 inches nominal and meets all other usable door requirements (Sections 3.123.13)?
- Acceptable Is there 30 x 48 inches of clear floor space outside the swing of the door that provides a side approach to the tub?
- Acceptable Is the clear floor space at the lavatory:
30 x 48 inches of clear floor space parallel to and centered on the sink basin; or a removable vanity cabinet to provide knee space for a forward approach?
- If knee space is provided at the lavatory:
- Acceptable Is no more than 19 inches of the 30 x 48 inches of required clear floor space extended under the lavatory?
- Acceptable Is The top fixture rim is a maximum of 34 inches, with the apron at least 27 inches?
- Acceptable Is the depth of the wall hung or countertop lavatory is at least 17 inches from the wall?
- Specification A & B Bathroom Toilets
- Is one of the following three clear floor spaces is provided at toilets:

Bathrooms (Continued)

The centerline of the toilet is 18 inches from the adjacent side wall and at least 15 inches from a wall-hung lavatory or vanity.

There is a minimum of 48 x 66 inches of clear floor space, excluding the toilet and the wallhung lavatory or vanity.

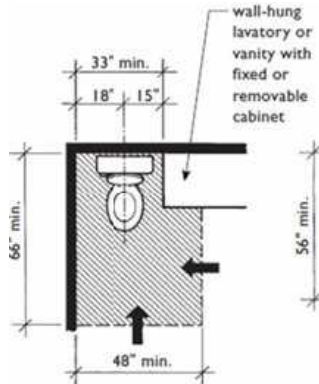

The centerline of the toilet is 18 inches from the adjacent side wall.

There is a minimum of 60 x 56 inches of clear floor space, excluding the toilet.

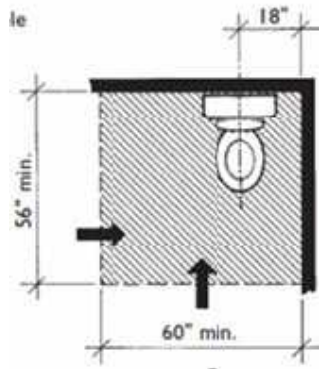

Is one of the following three clear floor spaces provided at tubs:

There is a minimum of 30 x 60 inches of clear floor space adjacent to the tub, excluding a lavatory with knee space.

Note: for use with Specification A bathrooms only.

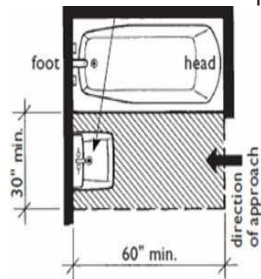

Specification "A"
 Bathrooms
 30" X 60"

Bathrooms (Continued)

There is a minimum of 48 x 60 inches of clear floor space adjacent to the tub, excluding a toilet with a centerline at least 18 inches from the tub.

Note: for use with Specification A bathrooms only.

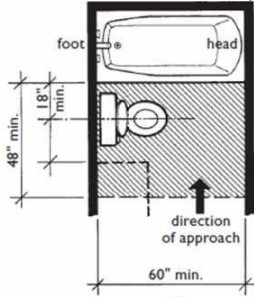

2
Specification "A"
Bathrooms
48" X 60"

There is a minimum of 30 x 48 inches of clear floor space adjacent to the tub.

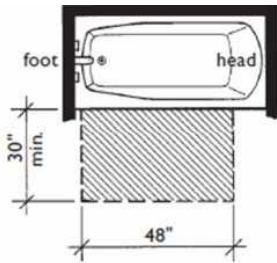

3
Specification "B"
Bathrooms
30" X 48"

Showers

Bathrooms (Continued)

254 Apartment Bathrooms

Usable bathrooms are included under Requirement 7 of the Fair Housing Act. A clear floor space positioned at fixtures and proper clearance, among other criteria, in order to provide accessibility to people with disabilities. is required.

Acceptable Is the bathroom is along an accessible route with a nominal 32-inch clear door opening?

Acceptable Are switches, outlets, and controls are located in accessible locations?

Acceptable Are walls are reinforced for the installation of grab bars?

Acceptable Is there is sufficient maneuvering space within the bathroom to permit a person to enter and exit the room, close and reopen the door, and use fixtures?

In instances where there is a powder room in the unit, is the powder room:

Acceptable Along an accessible route with a door that provides a nominal 32-inch clear opening; and

Acceptable Equipped with switches, outlets, and controls in accessible locations.

Acceptable In a multistory unit in an elevator building, is there either a usable powder room (Section 7.12) or a usable bathroom (Section 7.11) on the same level that is served by the elevator?

If only a powder room is provided on the level that is served by the elevator:

Acceptable Is there sufficient maneuvering space within the bathroom to permit a person to enter and exit the room, close and reopen the door, and use fixtures?

The Fair Housing Act provides two sets of specifications to design bathrooms that are usable by people with disabilities. Though there are other differences, Specification B Bathrooms offer greater access to the tub than Specification A Bathrooms.

If the Specification A design is selected, all bathrooms in the unit must comply with Specification A standards (Section 7.14). This includes access to all fixtures in each Specification A

Bathroom (e.g., two lavatories in one bathroom would both need to meet FHA regulations).

If the Specification B design is selected, only one bathroom in the unit, and only one of each type of fixture within the bathroom, must comply with Specification B standards (Section

7.15). All other bathrooms in the unit must meet the usable bathroom requirements (Section 7.11), exempting maneuvering clearances and clear floor space requirements at fixtures.

Specification A and B Bathrooms

Bathrooms (Continued)

Specification A Bathrooms

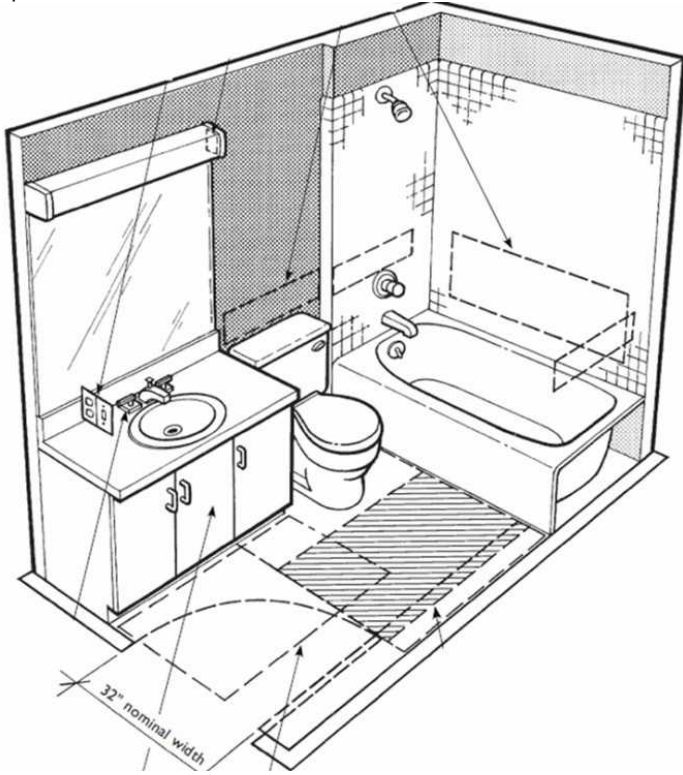

- Acceptable Does the door have a minimum clear width of 32 inches nominal and meets all other usable door requirements (Sections 3.12-3.13)?
- Acceptable Is there is 30 x 48 inches of clear floor space outside the swing of the door that provides a forward approach to the tub?
- Note: A parallel approach to the tub is also possible if proper knee space or removable base cabinets are provided.
- Acceptable Is the clear floor space at the lavatory:
30 x 48 inches of clear floor space parallel to and centered on the sink basin; or a removable vanity cabinet to provide knee space for a forward approach?

Bathrooms (Continued)

Specification B Bathrooms

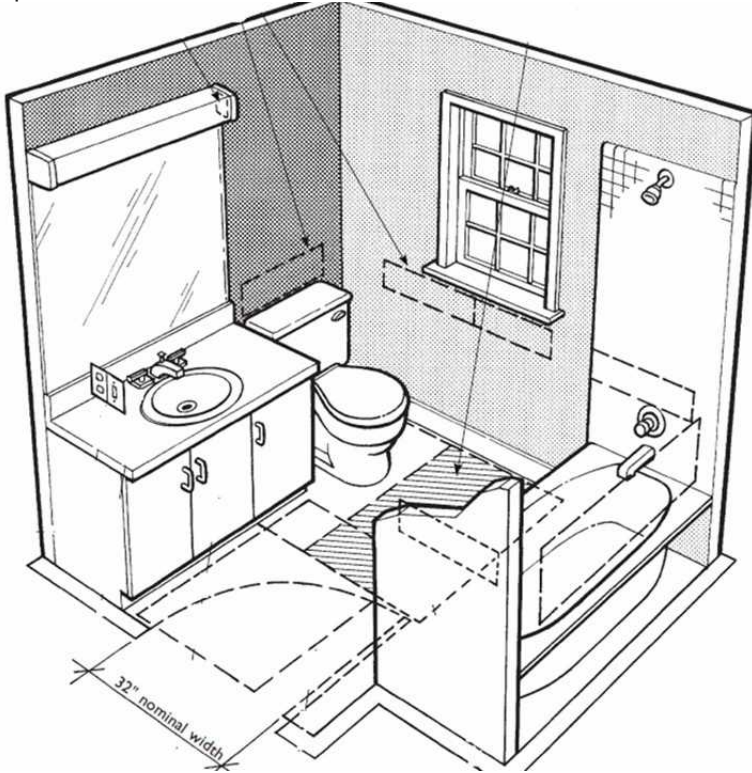

- Acceptable Does the door have a minimum clear width of 32 inches nominal and meets all other usable door requirements (Sections 3.123.13)?
- Acceptable Is there 30 x 48 inches of clear floor space outside the swing of the door that provides a side approach to the tub?
- Acceptable Is the clear floor space at the lavatory:
30 x 48 inches of clear floor space parallel to and centered on the sink basin; or a removable vanity cabinet to provide knee space for a forward approach?
- If knee space is provided at the lavatory:
- Acceptable Is no more than 19 inches of the 30 x 48 inches of required clear floor space extended under the lavatory?
- Acceptable Is The top fixture rim is a maximum of 34 inches, with the apron at least 27 inches?
- Acceptable Is the depth of the wall hung or countertop lavatory is at least 17 inches from the wall?
- Acceptable If a removable cabinetry is provided, are pipes are covered for protection by: Insulation around pipes; or a fixed, one-piece protection panel?

Specification A & B Bathroom Toilets

Is one of the following three clear floor spaces is provided at toilets:

Bathrooms (Continued)

The centerline of the toilet is 18 inches from the adjacent side wall and at least 15 inches from a wall-hung lavatory or vanity.

There is a minimum of 48 x 66 inches of clear floor space, excluding the toilet and the wallhung lavatory or vanity.

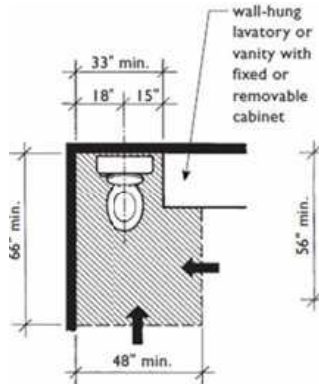

The centerline of the toilet is 18 inches from the adjacent side wall.

There is a minimum of 60 x 56 inches of clear floor space, excluding the toilet.

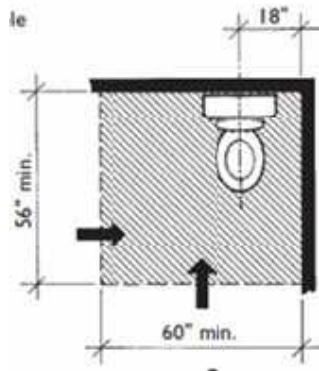

Is one of the following three clear floor spaces provided at tubs:

There is a minimum of 30 x 60 inches of clear floor space adjacent to the tub, excluding a lavatory with knee space.

Note: for use with Specification A bathrooms only.

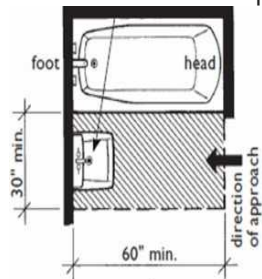

Specification "A"
 Bathrooms
 30" X 60"

Bathrooms (Continued)

There is a minimum of 48 x 60 inches of clear floor space adjacent to the tub, excluding a toilet with a centerline at least 18 inches from the tub.

Note: for use with Specification A bathrooms only.

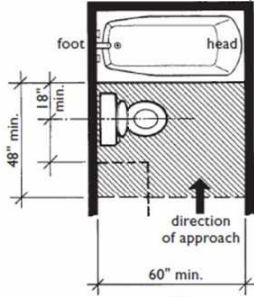

2
Specification "A"
Bathrooms
48" X 60"

There is a minimum of 30 x 48 inches of clear floor space adjacent to the tub.

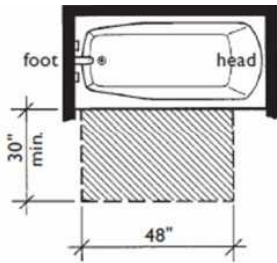

3
Specification "B"
Bathrooms
30" X 48"

Showers

Bathrooms (Continued)

Exercise Equipment

Exercise Machines & Equipment (2010 Standards 206, 236 & 1004)

Is there an accessible route to at least one of each type of exercise machine and equipment? Defective Move west treadmill 3 to east



Note: Most strength training equipment and machines are considered different types. For example, a bench press machine is different from a biceps curl machine. Cardiovascular exercise machines, such as stationary bicycles, rowing machines, stair climbers and treadmills, are all different types.

Is there clear floor space at least 30 inches wide by at least 48 inches long positioned for transfer or for use by a person seated in a wheelchair next to at least one of each type of exercise machine and equipment? Defective Move west treadmill to allow 36 access

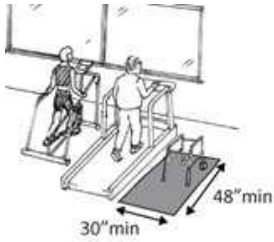

Notes:

1. To make a shoulder press accessible, the clear floor space should be next to the seat. For a bench press, the clear floor space should be centered on the operating mechanisms.
2. Machines and equipment can share clear floor space.
3. The exercise equipment and machines do not need to comply with the 2010 Standards specifications for controls and operating mechanism.

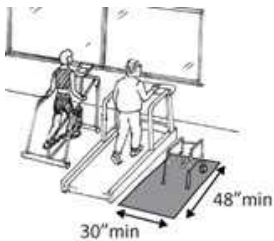

Exercise Equipment (Continued)

Pool

ADA pool

Swimming Pools, Wading Pools & Spas (2010 Standards 242 & 1009)

Defective

Is there an accessible route from the facility entrance to the swimming pool, wading pool and/or spa?
 Use the checklist for Priority 1: Approach & Entrance. Pool area gates require too much force to operate, greater than 5 lbs. West gate closes too fast - 5 seconds required from 90 - 15 degrees



Acceptable

Is there an accessible route from the facility entrance to the swimming pool, wading pool and/or spa?
 Use the checklist for Priority 2: Access to Goods & Services.



If there is a swimming pool with 300 or more linear feet of pool wall:

Defective

Does it have a sloped entry or lift? No accessible entry. Add lifts to pool and spa

Defective

If there is a spa, does it have a pool lift, transfer wall or transfer system?



Colorado Inspection Services, LLC

Prepared for:
1 Main St

Pool (Continued)

Marginal Summary

This summary is not the entire report. The complete report may include additional information of concern to the client. It is recommended that the client read the complete report.

Parking

1. Parking II Is at least 98 inches of vertical clearance provided for the van accessible space?
[502.5] Only on first floor. Van space must be on 1st floor. Add another space with adequate unloading area on the passenger side.

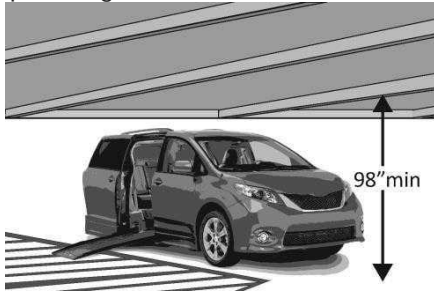

Defective Summary

This summary is not the entire report. The complete report may include additional information of concern to the client. It is recommended that the client read the complete report.

Parking

1. Parking II Of the accessible spaces, is at least one a van accessible space?*[208.2.4]
For every 6 or fraction of 6 accessible parking spaces required, at least one must be a van accessible space. None - two required. These must be one the first floor due to height limitations on higher floors.
2. Parking II Is the van accessible space:
At least 11 feet wide with an access aisle at least 5 feet wide?
Or
At least 8 feet wide with an access aisle at least 8 feet wide?
[502.2] None

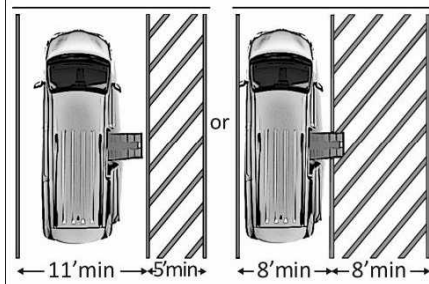

3. Parking II Are there signs reading "van accessible" at van accessible spaces?
[502.6]
no

Entry

4. Entry If the door has a closer, does it take at least 5 seconds to close from an open position of 90 degrees to a position of 12 degrees from the latch?
[404.2.8]

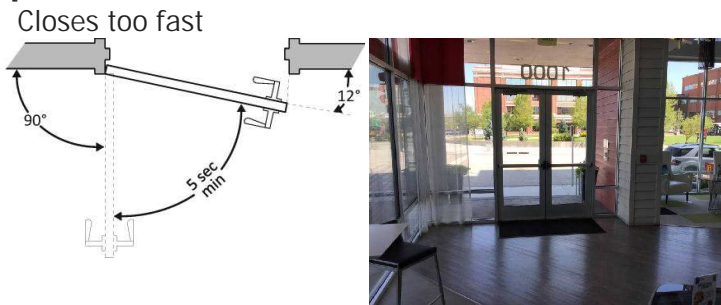

Common Areas

5. Common Spaces If the door has a closer, does it take at least 5 seconds to close from an open position of 90 degrees to a position of 12 degrees from the latch?
[404.2.8]
Doors to courtyard too fast

Common Areas (Continued)

If the door has a closer, does it take at least 5 seconds to close from an ... (continued)

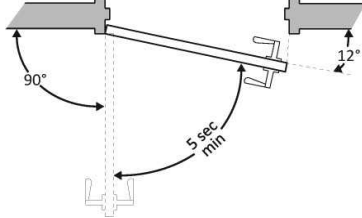

6. Common Spaces Is there an accessible route leading to at least one of each type of feature within each common use area. Examples include:
 Fitness equipment within fitness centers
 Laundry machines and folding tables within laundry rooms
 Pool tables and games within clubhouses
 Access lanes too narrow to TV room. 36 min required - move couch.



Restrooms

7. Lock (if provided)?
 [404.2.7]
 Lock requires grasp



8. Can the door be opened easily (5 pounds maximum force)?
 [404.2.9]
 Note: You can use a pressure gauge or fish scale to measure force. If you do not have one you will need to judge whether the door is easy to open. no

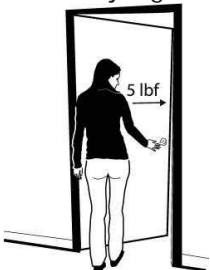

Defective Summary (Continued)

9. If the door has a closer, does it take at least 5 seconds to close from an open position of 90 degrees to a position of 12 degrees from the latch?

[404.2.8.1] closes too fast

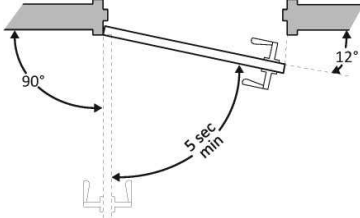

10. Can the door be opened easily (5 pounds maximum force)?

[404.2.9]

Note: You can use a pressure gauge or fish scale to measure force. If you do not have one you will need to judge whether the door is easy to open. Womens room greater than 5 lbs required

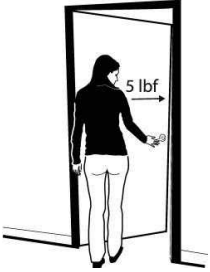

11. If the door has a closer, does it take at least 5 seconds to close from an open position of 90 degrees to a position of 12 degrees from the latch?

[404.2.8.1] Womens door closes too fast.

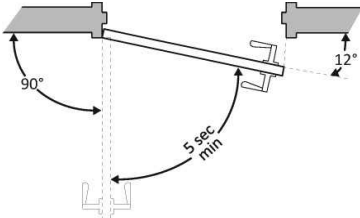

12. Lock (if provided)?

[404.2.7]

Requires grasp



Defective Summary (Continued)

13. If the door has a closer, does it take at least 5 seconds to close from an open position of 90 degrees to a position of 12 degrees from the latch?
[404.2.8.1] West door closes too fast.

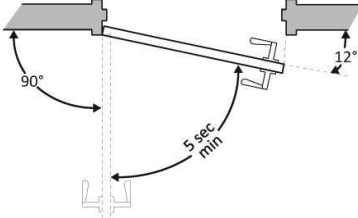

Kitchens

14. One Bedroom Apartment Kitchens All pipes are covered by a removable pipe protection and panel, or wrapped with padded insulation materials.

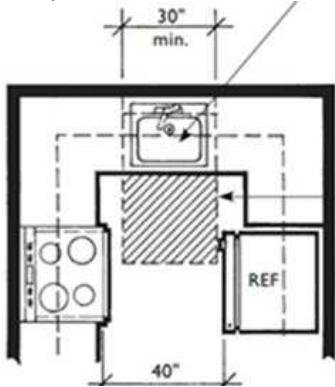

15. Two Bedroom Apartment Kitchens In instances where kitchens have an island, the 40-inch minimum clearance is maintained around all edges within the kitchen work area? Refrigerator decreases path to less than 40"

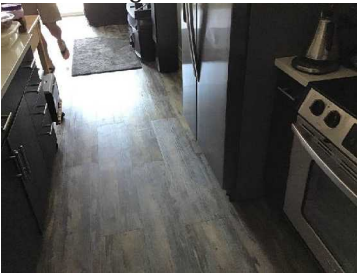

16. Two Bedroom Apartment Kitchens All pipes are covered by a removable pipe protection and panel, or wrapped with padded insulation materials.

Kitchens (Continued)

All pipes are covered by a removable pipe protection and panel, or wrapped ... (continued)

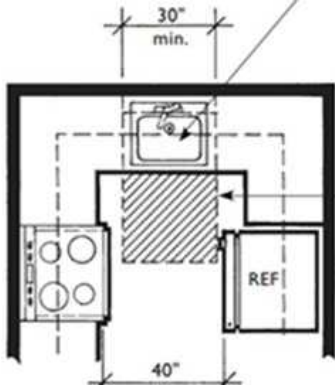

Exercise Equipment

17. Exercise Machines & Equipment (2010 Standards 206, 236 & 1004) Is there an accessible route to at least one of each type of exercise machine and equipment? Move west treadmill 3 to east



18. Exercise Machines & Equipment (2010 Standards 206, 236 & 1004) Is there clear floor space at least 30 inches wide by at least 48 inches long positioned for transfer or for use by a person seated in a wheelchair next to at least one of each type of exercise machine and equipment? Move west treadmill to allow 36 access

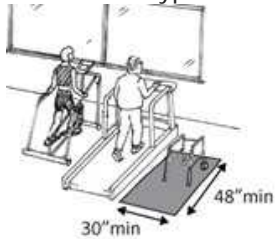

Pool

19. ADA pool Is there an accessible route from the facility entrance to the swimming pool, wading pool and/or spa? Use the checklist for Priority 1: Approach & Entrance. Pool area gates require too much force to operate, greater than 5 lbs. West gate closes too fast - 5 seconds required from 90 - 15 degrees





Colorado Inspection Services, LLC

Prepared for:
1 Main St

Defective Summary (Continued)

- 20. ADA pool Does it have a sloped entry or lift? No accessible entry. Add lifts to pool and spa
- 21. ADA pool If there is a spa, does it have a pool lift, transfer wall or transfer system?